

FB-V51A

パーツブック
PARTS BOOK

超々高速 2本縫オーバーロックミシン
ULTRA HIGH SPEED TWIN NEEDLE OVERLOCK SEWING MACHINE

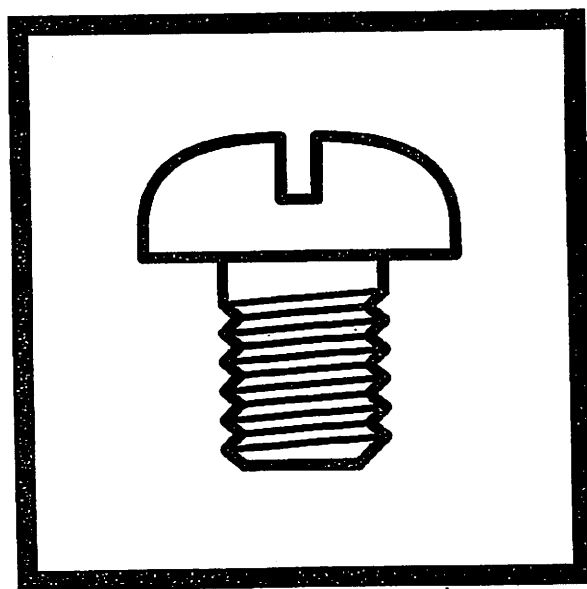

brother®

BROTHER INDUSTRIES, LTD. NAGOYA JAPAN

FB-V51A- ①②③④⑤⑥

仕様/Specifications

装置/Devices

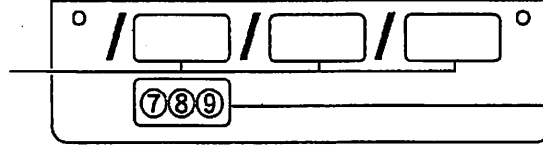

仕様明細/Detail of specifications

①

縫い目形式 / Stitch form	
W	2本針縁かがり・2本掛け Twin needle over-edge chain stitch, standard stitch
M	2本針縁かがり・1本外し Twin needle over-edge chain stitch, mock safety stitch

⑥

かがり幅 / Stitch width	
4	4 mm
5	5 mm
6	6 mm
7	7 mm

②

用途 / Applications	
0	地縫い / Plain seaming
4	ひだ取り / Ruffling
5	テープ付け / Taping
6	パイピング付ひだ取り / Ruffling with piping
8	バックタック / Back tacking

⑦

上ルミバリフォム / Overlooper locus	
S	スタンダード / Standard lift
H	ハイリフト / High lift
E	超ハイリフト / Extra high lift

③

縫製物 / Sewing materials	
1	極薄物～薄物 / Extra light - light materials
2	薄物～中厚物 / Light - medium materials
3	中厚物～厚物 / Medium - heavy materials
4	厚物～極厚物 / Heavy - Extra heavy materials
5	極厚物 / Extra heavy materials
6	バルキーニット / Bulky knit
7	極厚バルキーニット / Extra heavy bulky knit
S	新素材 / New synthetic fiber

⑧

差動送り幅 / 針板チェーンランド / Differential feed dog	
2	2列 / チェンランドあり 2-row / with chain land
3	3列 / チェンランドあり 3-row / with chain land
4	4列 / チェンランドあり 4-row / with chain land
2	2列 / チェンランドなし 2-row / without chain land
3	3列 / チェンランドなし 3-row / without chain land
4	4列 / チェンランドなし 4-row / without chain land

④

特用途 / Special use	
0	標準 / Standard
1	小回り仕様 / Small type
S	セミオートバックタック / Semi auto backtack

⑨

メス形状 / Upper knife shape	
F	平メス / Flat knife
A	角メス / Angle knife
B	角メス幅広 / Angle knife, wide
V	角メス波刃 / Angle knife, wave shape
W	角メス幅広波刃 / Angle knife, wave shape

⑤

針幅 / Needle gauge	
2	2.2mm
3	2.5mm
5	3mm

パーツブックご利用に際して

1. この本は、この本の表紙(正誤表の挿入されている場合は正誤表)に記載されているものと同じプレートが取り付けられているミシンのためのものです。
2. この本は、1998年11月のデータに基づいて作成されたものです。
3. 部品は予告なしに設計変更される場合があります。
4. 組単位で補給する部品は、[] 破線で示しております。
5. 部品コード欄が※となっている場合は、ゲージ部品一覧表(43-47ページ)でお調べ下さい。

目 次

A. 主体関係	1
B. 駆動軸関係	5
C. 針棒関係	7
D. 押工関係	9
E. 送り関係	15
G. 上メス・下メス関係	19
H. 上ルーバ関係	21
J. 下ルーバ関係	23
L. 給油潤滑関係	25
M. 糸調子関係	27
P. 針冷却関係	29
Q. 縁カガリ定規関係	29
R. ラフラー装置関係	31
S. バックタック関係	37
Z. 付属品関係	39
Ga. ゲージ部品一覧表	43
Wa. 警告ラベル	48
索引	49

Notes for using this parts book

1. This book is applicable to sewing machines which have the same plate number as shown on the cover of this book (or correction sheet).
2. This book was prepared based on information available in November 1998.
3. Parts are subject to changes in design without prior notice.
4. Parts supplied as complete assemblies are circled by a dotted line [] .
5. If the symbol ✕ is found in the "Parts No." column, refer to the different parts list on page 43-47 .

CONTENTS

A. Machine body	1
B. Crankshaft mechanism	5
C. Needle bar mechanism	7
D. Presser foot mechanism	9
E. Feed mechanism	15
G. Knife mechanism	19
H. Over looper mechanism	21
J. Under looper mechanism	23
L. Lubrication	25
M. Thread tension	27
P. Needle cooler	29
Q. Serging attachment	29
R. Ruffling attachment	31
S. Back-tacking	37
Z. Accessories	39
Ga. Gauge parts List	43
Wa. Warning labels	48
INDEX	49

A. 主体関係 / Machine body

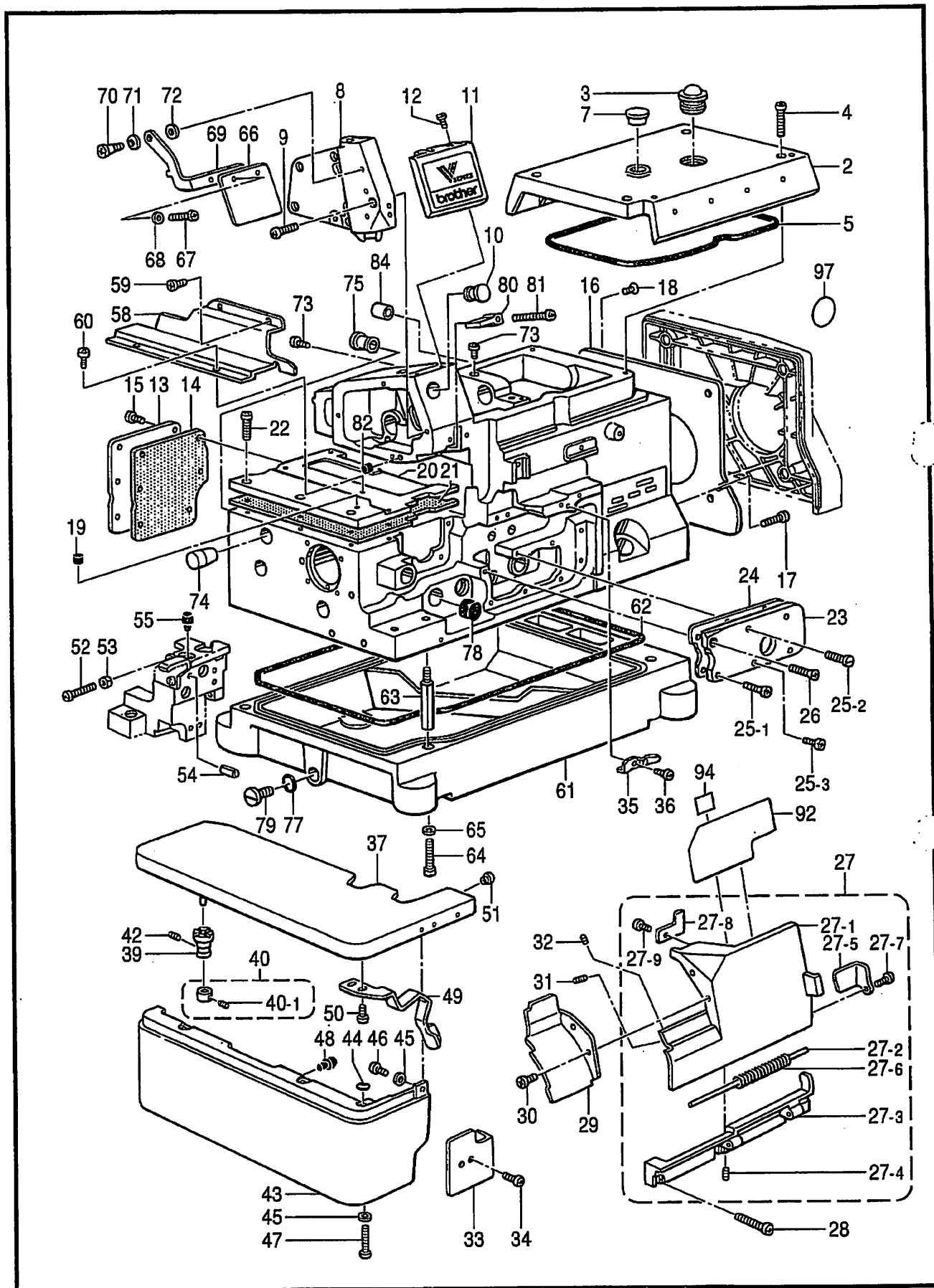

878-V5A-052

A. 主体関係 / Machine body

REF.NO.	CODE	Q'TY	ヒンメイ	NAME OF PARTS	RM
2	S20305001	1	ウワカバー	TOP COVER	
3	S02606000	1	ユリヨウケイマド	OIL GAUGE WINDOW	
4	062401212	4	ナベコ4X12	SCREW, PAN M4X12	
5	S20306000	1	パツキン	PACKING	
7	S23337009	1	ゴムセン18.5	RUBBER CAP, 18.5	
8	S39607001	1	ソクメンカバー	FRAME SIDE COVER	
9	062400812	5	ナベコ4X8	SCREW, PAN M4X8	
10	S20345009	1	ゴムセン14	RUBBER CAP, 14	
11	S20309101	1	メンイタカバー	FACE PLATE COVER	
12	060400612	2	バインドM4X6	SCREW, BIND M4X6	
13	S20310001	1	オクリキコウカバー-B	COVER FOR FEED MECHANISM, B	
14	S20311000	1	パツキン	PACKING	
15	060400812	6	バインドM4X8	SCREW, BIND M4X8	
16	S23367001	1	ファンカバー	FAN COVER	
17	060400812	2	バインドM4X8	SCREW, BIND M4X8	
18	061400812	1	サラコM4X8	SCREW, FLAT M4X8	
19	S20878000	1	ゴムセン5.3	RUBBER CAP, 5.3	
20	S20313000	1	オクリダイカバー	FEED BAR COVER	
21	S20314000	1	パツキン	PACKING	
22	062401012	6	ナベコM4X10	SCREW, PAN M4X10	
23	S39564021	1	ウチカバー	INSIDE COVER	
24	S44536000	1	ウチカバーパツキン	PACKING, INSIDE COVER	
25-1	060401012	3	バインドM4X10	SCREW, BIND M4X10	
25-2	S23616101	1	シメネジ4X10	SCREW, M4X10	
25-3	S44535001	1	バインドM4X8シール	SCREW, BIND M4X8 SEAL	
26	061400812	1	サラコM4X8	SCREW, FLAT M4X8	
27	S39611001	1	マエカバー-Lクミ	FRONT COVER ASSY, L	
27-1	S39612001	1	マエカバー-L	FRONT COVER, L	
27-2	S39613001	1	マエカバーヒンジジク	FRONT COVER HINGE SHAFT	
27-3	S20319001	1	マエカバーヒンジ	FRONT COVER HINGE	
27-4	012400432	2	アナヒラ4X4	SET SCREW, SOCKET (FT) M4X4	
27-5	S20320101	1	マエカバーストツバ	FRONT COVER STOPPER	
27-6	S20321001	1	マエカバーバネ	FRONT COVER SPRING	
27-7	060400612	1	バインドM4X6	SCREW, BIND M4X6	
27-8	S20327101	1	マエカバートメイタ	STOPPER PLATE, FRONT COVER	
27-9	060400612	1	バインドM4X6	SCREW, BIND M4X6	
28	060401412	3	バインドM4X14	SCREW, BIND M4X14	
29	S20323101	1	マエカバー-S	FRONT COVER, S	
30	062400612	2	ナベコM4X6	SCREW, PAN M4X6	
31	012400832	1	アナヒラ4X8	SET SCREW, SOCKET (FT) M4X8	
32	012400432	1	アナヒラ4X4	SET SCREW, SOCKET (FT) M4X4	
33	S20324101	1	マエカバー-Lアンナイ	FRONT COVER GUIDE, L	
34	060400612	2	バインドM4X6	SCREW, BIND M4X6	
35	S20325001	1	マエカバートメイタバネ	PLATE SPRING	
36	060400612	1	バインドM4X6	SCREW, BIND M4X6	
37	S20328001	1	クロスプレート	CLOTH PLATE	
39	S20330100	1	クロスプレートササエカラー	CLOTH PLATE SUPPORT COLLAR	
40	S20331001	1	セツトカラークミ	SET SCREW COLLAR ASSY	
40-1	012400432	1	アナヒラ4X4	SET SCREW, SOCKET (FT) M4X4	
42	012400632	1	アナヒラ4X6	SET SCREW, SOCKET (FT) M4X6	
43	S20334000	1	クロスプレートシタ	CLOTH PLATE (LOWER)	
44	118770001	3	パツキン	PACKING	
45	025040132	4	ヒラザガネシヨウ4	WASHER, PLAIN S 4	
46	060400612	1	バインドM4X6	SCREW, BIND M4X6	
47	060401012	3	バインドM4X10	SCREW, BIND M4X10	
48	S20412000	2	ゴムセン3.7	RUBBER CAP, 3.7	
49	S39625151	1	クロスプレートトメイタバネ	SPRING, PLATE	
50	060400612	2	バインドM4X6	SCREW, BIND M4X6	
51	156482000	1	セン4	CAP, 4	

A. 主体関係 / Machine body

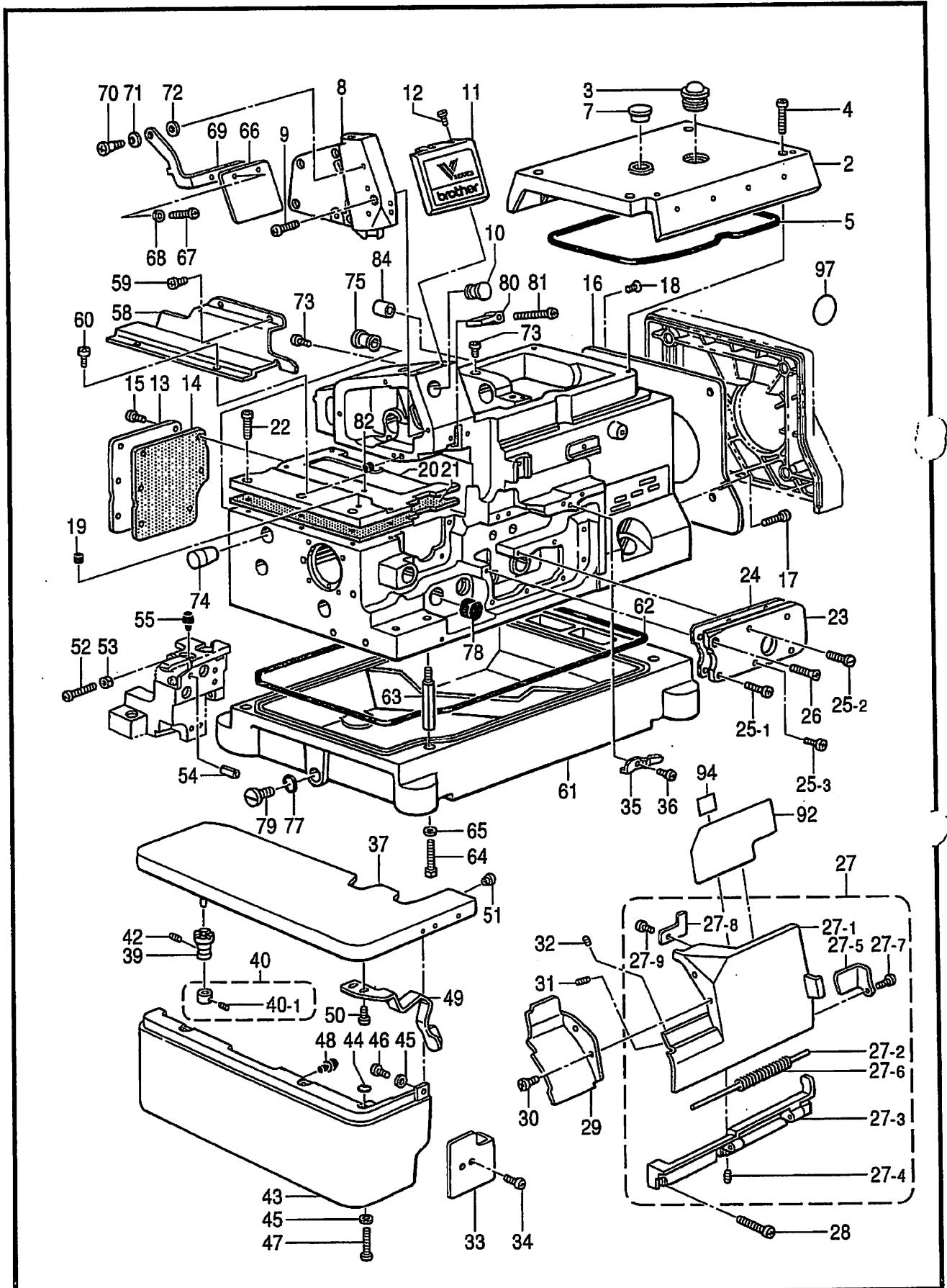

878-V5A-052

A. 主体関係 / Machine body

REF.NO.	CODE	Q'TY	ヒンメイ	NAME OF PARTS	R/M
52	062401212	1	ナベコ4X12	SCREW, PAN M4X12	
53	021400212	1	2シユナツト4	NUT, 2 M4	
54	047602042	1	スプリングピン6X20	PIN, SPRING ROLL 6X20	
55	S20412000	1	ゴムセン3.7	RUBBER CAP, 3.7	
58	S39626021	1	クロスプレートヌノアンナイ	CLOTH GUIDE	
59	060400612	2	バインドM4X6	SCREW, BIND M4X6	
60	060400512	1	バインドM4X5	SCREW, BIND M4X5	
61	S20338200	1	アブラウケ	OIL PAN	
62	S20339000	1	パツキン	PACKING	
63	S23350001	4	ホントイシチュウ	MACHINE BODY LEG	
64	017501212	4	ボルト5X12	BOLT, M5X12	
65	S23351001	4	ザガネ	WASHER	
66	S00075000	1	アイガード	EYE GUARD	
67	060350812	2	バインド35X8	SCREW, BIND M3.5X8	
68	025350332	2	ヒラザガネダイ3.5	WASHER, PLAIN L 3.5	
69	S20340001	1	アイガードササエイタ	EYE GUARD SUPPORT PLATE	
70	S20342001	1	ダンネジ4	SHOULDER SCREW, M4	
71	146598001	1	バネザガネ	WASHER, SPRING	
72	025050132	1	ヒラザガネシヨウ5	WASHER, PLAIN S 5	
73	S30517101	5	ナベコシール6X10	SCREW, PAN M6X10 SEAL	
74	S20344009	1	ゴムセン16	RUBBER CAP, 16	
75	S20345009	1	ゴムセン14	RUBBER CAP, 14	
77	081009070	1	OリングP9	O RING, P9	
78	154841001	1	ゴムセン16.8	RUBBER CAP, 16.8	
79	S23357001	1	シメネジ10	SCREW, M10	
80	S20346000	1	ハリボウアブラウケ	NEEDLE BAR OIL RESERVOIR	
81	062401612	1	ナベコM4X16	SCREW, PAN M4X16	
82	S20878000	1	ゴムセン5.3	RUBBER CAP, 5.3	
84	S07477009	1	ゴムリング	RUBBER RING	
92	S25181001	1	イトトオシセツメイラベルC	THREADING DIAGRAM LABEL (C)	
94	S44821001	1	セイソウシジラベル	LABEL, CLEANING	
97	S43453001	1	フィルタコウカンシジラベル	LABEL, CLEANING FILTER	

B. 駆動軸関係 / Driving shaft mechanism

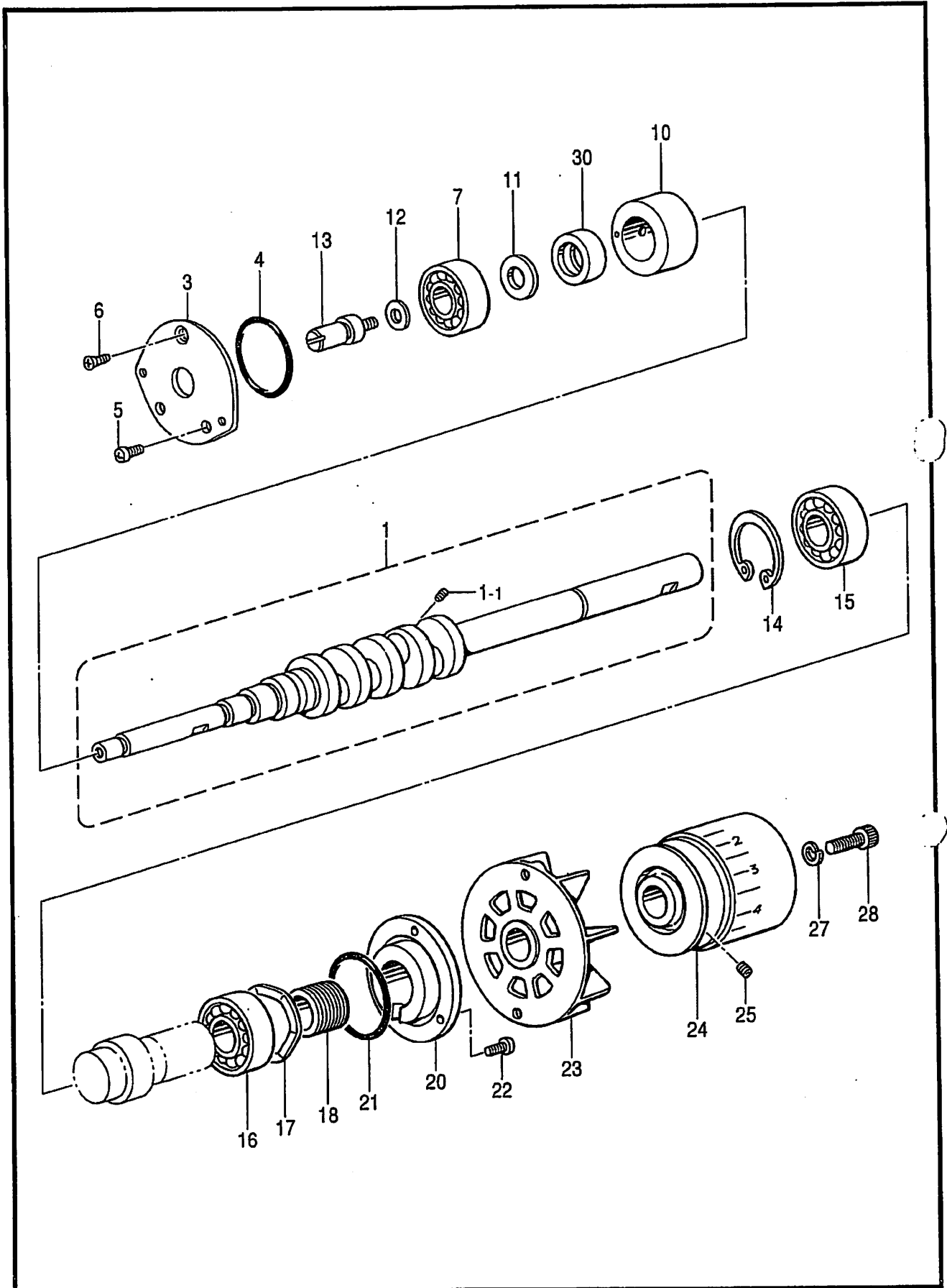

B. 駆動軸関係 / Crankshaft mechanism

REF.NO.	CODE	Q'TY	ヒンメイ	NAME OF PARTS	RM
1	S46921001	1	<ハイリフト用> クドウジクOネジツキ	<FOR HIGH-LIFT> CRANKSHAFT, O W/SCREW	
1	S46922001	1	<超ハイリフト用> クドウジクPネジツキ	<FOR EXTRA HIGH-LIFT> CRANKSHAFT, O W/SCREW	
1-1	S25530001	1	アナコボミ2.5X4	SET SCREW, SOCKET M2.5X14	
3	S39629021	1	ベアリングフタ	BEARIG CAP	
4	081031870	1	Oリング S31.5	O RING S31.5	
5	062400812	2	ナベコ4X8	SCREW, PAN M4X8	
6	061400812	1	サラコM4X8	SCREW, FLAT M4X8	
7	072600000	1	タマジクウケ6000	BALL BEARING, 6000	
10	S39630000	1	クドウジクメタル	CRANK SHAFT BUSH	
11	S20356001	1	ヒラザガネ10	WASHER, PLAIN 10	
12	155559001	1	ヒラザガネ	WASHER, PLAIN	
13	S46900001	1	ニジユウカンテンピンジク	D-CHAIN STITCH THR. TAKE-UP SHAFT	
14	048400242	1	トメワアナヨウC40	RETAINING RING, C40	
15	076203000	1	タマジクウケ6203	BALL BEARING, 6203	
16	S27868001	1	タマジクウケ6203V	BALL BEARING, 6203V	
17	S20361001	1	ナミバネ	SPRING, WAVE	
18	S20362151	1	クドウジクオイルキリ	CRANK SHAFT OIL REJECTOR	
20	S39631000	1	ベアリングオサエ	BEARING PRESSER	
21	S20353000	1	Oリング	O RING	
22	062401012	3	ナベコM4X10	SCREW, PAN M4X10	
23	S20366000	1	ファン	FAN	
24	S39565101	1	プーリ	PULLEY	
25	012060632	2	アナヒラ6X6	SET SCREW, SOCKET (FT) M6X6	
27	028060242	1	バネザガネ2-6	WASHER, SPRING 2-6	
28	018062532	1	アナホルト6X25	BOLT, SOCKET M6X25	
30	S20357000	1	ニジユウカンヘンシンカバー	CHAIN STITCH ECCENTRIC COVER	

C. 針棒關係 / Needle bar mechanism

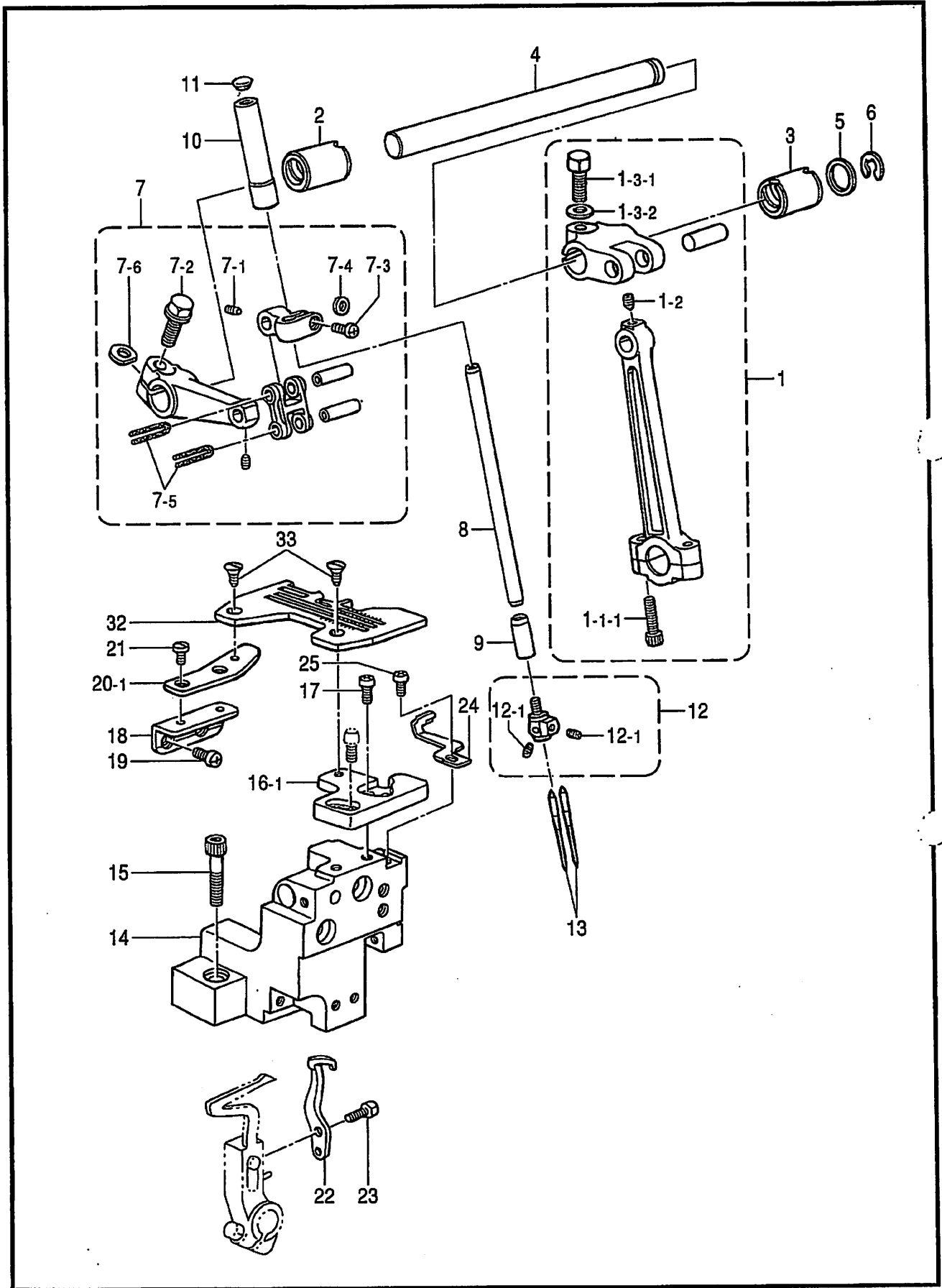

C. 針棒関係 / Needle bar mechanism

REF.NO.	CODE	Q'TY	ヒンメイ	NAME OF PARTS	RM
1	S46931001	1	<ハイリフト用> ハリクランクロッドクミH	<FOR HIGH-LIFT> N-DRIVING CRANK ROD ASSY, H	
1	S46932001	1	<超ハイリフト用> ハリクランクロッドクミE	<FOR EXTRA HIGH-LIFT> N-DRIVING CRANK ROD ASSY, S	
1-1-1	018401622	2	アナボルト4X16	BOLT, SOCKET M4X16	
1-2	S23342001	1	アナトガリ4X5	SET SCREW, SOCKET (CN) M4X5	
1-3-1	017061612	1	ボルト6X16	BOLT, M6X16	
1-3-2	118735002	1	ザガネ	WASHER	
2	S39644021	1	ハリジクメタルL	NEEDLE SHAFT BUSH, L	
3	S39645021	1	ハリジクメタルR	NEEDLE SHAFT BUSH, R	
4	S39646021	1	ハリジク	NEEDLE SHAFT	
5	S39647000	1	ザガネ	WASHER	
6	146293001	1	トメワE10	RETAINING RING, E10	
7	S20386101	1	ハリボウダクミ	NEEDLE BAR CLAMP ASSY	
7-1	S23342001	2	アナトガリ4X5	SET SCREW, SOCKET (CN) M4X5	
7-2	S46899001	1	ザガネツキボルト6X16	BOLT, (S/P WASHER) M6X16	
7-3	062350812	1	ナベコ3.5X8	SCREW, PAN M3.5X8	
7-4	S20391001	1	スパーサ	SPACER	
7-5	S20392000	2	フェルト	FELT	
7-6	155162001	1	スパーサ	SPACER	
8	S20393101	1	ハリボウ	NEEDLE BAR	
9	S39648021	1	ハリボウメタルD	NEEDLE BAR BUSH, D	
10	S39571021	1	ハリボウメタルU	NEEDLE BAR BUSH, U	
11	104450101	1	ゴムセン8	RUBBER CAP, 8	
12	※	1	ハリドメクミ	NEEDLE CLAMP ASSY	
12-1	146427001	2	アナトメネジ3.18クボミ	SET SCREW, SOCKET (CP) SM3.18	
13	※	2	ミシンハリDCX27	NEEDLE, DCX27	
14	S39649021	1	ハリイタササエダイ	NEEDLE PLATE SUPPORT BRACKET	
15	018062532	2	アナボルト6X25	BOLT, SOCKET M6X25	
16-1	S39650051	1	ハリイタササエイタF	NEEDLE PLATE SUPPORT, F	
17	062401012	2	ナベコM4X10	SCREW, PAN M4X10	
18	S20413051	1	ハリイタササエイタBササエ	SUPPORT, B N-PLATE SUPPORT	
19	062400612	2	ナベコM4X6	SCREW, PAN M4X6	
20-1	S20414001	1	ハリイタササエイタB	NEEDLE PLATE SUPPORT PLATE, B	
21	S23418002	2	シメネジ4X5	SCREW, M4X5	
22	S20415101	1	イドウハリウケ	MOVABLE NEEDLE GUARD	
23	S20416101	1	ボルト3.5X10	BOLT, M3.5X10	
24	S39653051	1	ハリウケF	NEEDLE GUARD, F	
25	062350812	1	ナベコ3.5X8	SCREW, PAN M3.5X8	
32	※	1	ハリイタ	NEEDLE PLATE	
33	100032003	2	サラネジ4.37	SCREW, FLAT SM4.37	

D . 押工関係 / Presser foot mechanism

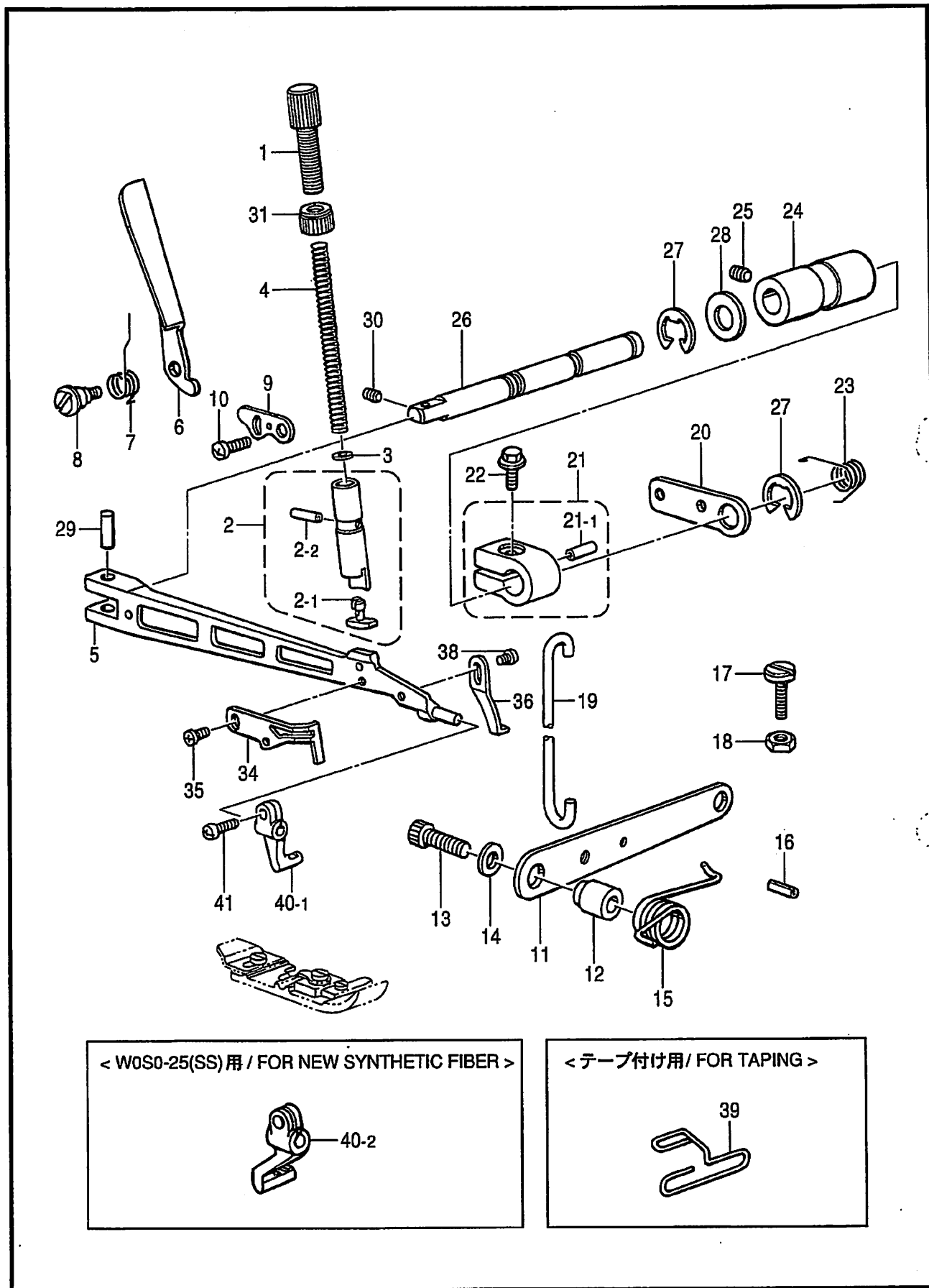

D. 押工関係 / Presser foot mechanism

REF.NO.	CODE	Q'TY	ヒンメイ	NAME OF PARTS	RM
1	S20472001	1	オサエチヨウセツネジ	ADJUST SCREW	
2	S46887001	1	オサエボウクミ	PRESSER BAR ASSY	
2-1	S39577000	1	オサエクツシヨン	CUSHION	
2-2	047301642	1	スプリングピンAW3	PIN, SPRING ROLL AW3	
3	105161004	1	ザガネ	WASHER	
4	S20476001	1	オサエバネ	PRESSER SPRING	
5	S46889001	1	シユオサエウデ	MAIN PRESSER ARM	
6	S39659021	1	オサエテアゲ	PRESSER BAR LIFTER	
7	S39660001	1	オサエテアゲバネ	PRESSER BAR LIFTER SPRING	
8	S39661001	1	ダンネジ4	SHOULDER SCREW, M4	
9	S39662001	1	シユオサエウデストツバ	MAIN PRESSER ARM STOPPER	
10	060400612	1	バインドM4X6	SCREW, BIND M4X6	
11	S39663021	1	オサエアシアゲレバー	PRESSER FOOT LIFTER LEVER	
12	S39664001	1	オサエアシアゲレバーカラー	COLLAR	
13	018062532	1	アナホルト6X25	BOLT, SOCKET M6X25	
14	025060332	1	ヒラザガネダイ6	WASHER, PLAIN L 6	
15	S39665001	1	オサエアシアゲレバーバネ	SPRING	
16	047502542	1	スプリングピンAW5	PIN, SPRING ROLL AW5	
17	S39770001	1	シメネジ4	SCREW, M4	
18	021400212	1	2シユナツト4	NUT, 2 M4	
19	S20485001	1	オサエアゲリンク	PRESSER BAR LIFTER LINK	
20	S39666001	1	オサエアゲレバー	PRESSER BAR LIFTER LEVER	
21	S46849001	1	オサエアゲウデクミ	PRESSER BAR LIFTER ARM ASSY	
21-1	047401642	1	スプリングピンAW4	PIN, SPRING ROLL AW4	
22	S46899001	1	ザガネツキボルト6X16	BOLT, (S/P WASHER) M6X16	
23	S39669101	1	オサエアゲレバーバネ	SPRING, PRESSER LIFTER LEVER	
24	S39670000	1	オサエウデジクメタル	PRESSER ARM SHAFT BUSH	
25	012060632	1	アナヒラ6X6	SET SCREW, SOCKET (FT) M6X6	
26	S39671101	1	オサエウデジク	PRESSER ARM SHAFT	
27	048090342	2	トメワE9	RETAINING RING, E9	
28	S30562000	1	ザガネ	WASHER	
29	S39672001	1	オサエウデピン	PRESSER ARM PIN	
30	012400432	1	アナヒラ4X4	SET SCREW, SOCKET (FT) M4X4	
31	S23341009	1	チヨウセツネジツマミナツト	NUT	
34	S37070121	1	フィンガーガードV	FINGER GUARD, V	
35	060300412	1	バインドM3X4	SCREW, BIND M3X4	
36	S20495001	1	オサエストツバ	PRESSER FOOT STOPPER	
38	060300612	1	バインドM3X6	SCREW, BIND M3X6	
40-1	S20494001	1	フクオサエウデ	SUB PRESSER ARM	
41	062670712	1	ナベコ357-40X7	SCREW, PAN SM3.57-40X7	
			<W050-25(SS) 用>	<FOR NEW SYNTHETIC FIBER >	
4	S20477001	1	オサエバネ	PRESSER SPRING	
40-2	S36870001	1	フクオサエウデ	SUB PRESSER ARM	
			<テープ付け用>	<FOR TAPING>	
39	S23364000	1	テープアンナイ	TAPE GUIDE	

D. 押工關係 / Presser foot mechanism

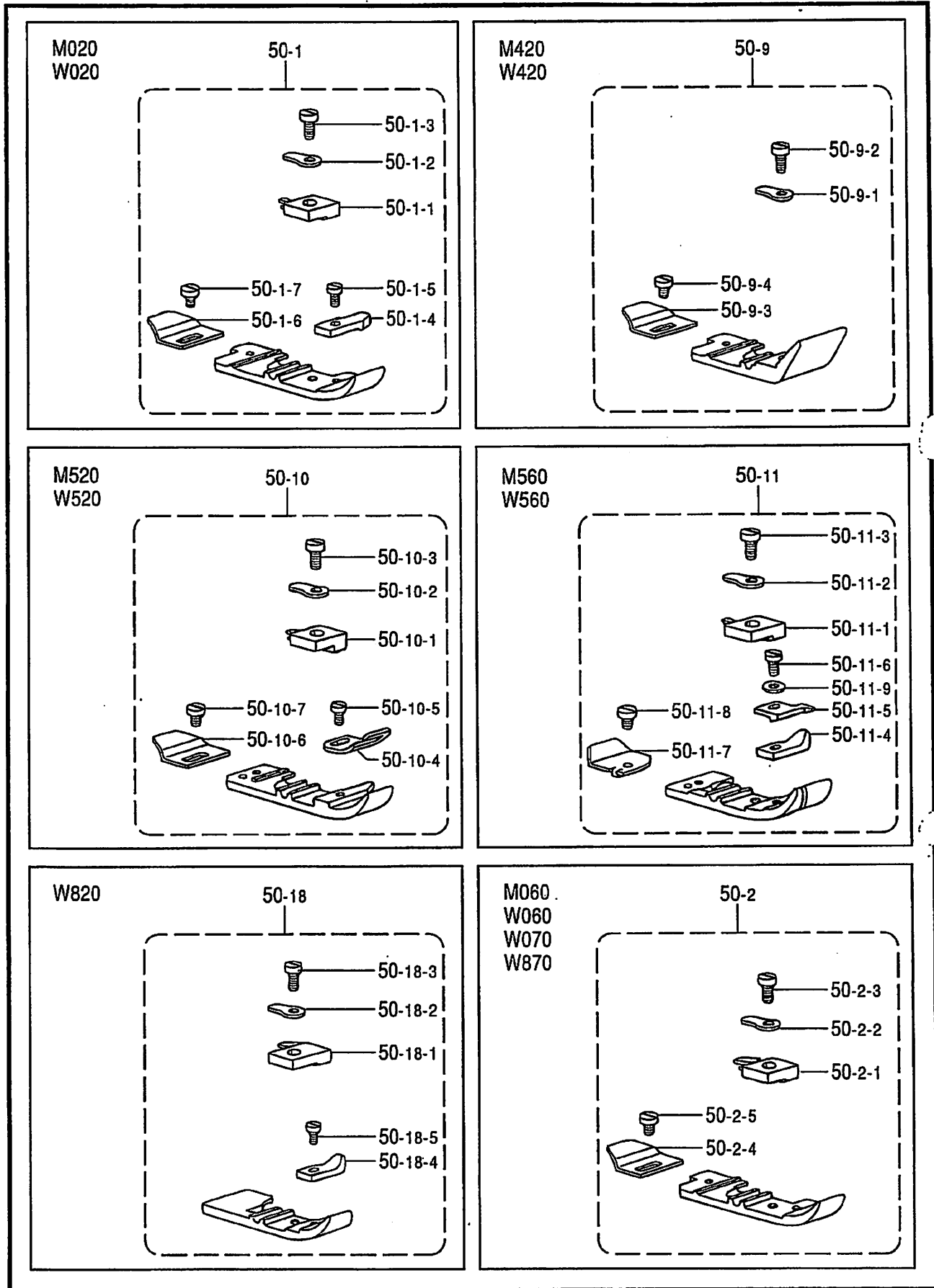

D. 押工関係 / Presser foot mechanism

REF.NO.	CODE	Q'TY	品名	NAME OF PARTS	RM
			<M020,W020>		
50-1	※	1	オサエクミ	PRESSER FOOT ASSY	
50-1-1	※	1	ツメ	STITCH TONGUE	
50-1-2	S19496001	1	オサエトリツケイタ	PRESSER FOOT PLATE	
50-1-3	150755001	1	シメネジ3.18	SCREW, SM3.18	
50-1-4	S19258001	1	オサエF	PRESSER FOOT, F	
50-1-5	S01295001	1	シメネジ2.38X3.5	SCREW, SM2.38X3.5	
50-1-6	S19259001	1	オサエB	PRESSER FOOT, B	
50-1-7	140530002	1	シメネジ2.38	SCREW, SM2.38	
			<M420,W420>		
50-9	※	1	オサエクミ	PRESSER FOOT ASSY	
50-9-1	S19496001	1	オサエトリツケイタ	PRESSER FOOT PLATE	
50-9-2	106640001	1	シメネジ3.18	SCREW, SM3.18	
50-9-3	S19259001	1	オサエB	PRESSER FOOT, B	
50-9-4	140530002	1	シメネジ2.38	SCREW, SM2.38	
			<M520,W520>		
50-10	※	1	オサエクミ	PRESSER FOOT ASSY	
50-10-1	※	1	ツメ	STITCH TONGUE	
50-10-2	S19496001	1	オサエトリツケイタ	PRESSER FOOT PLATE	
50-10-3	150755001	1	シメネジ3.18	SCREW, SM3.18	
50-10-4	S19296001	1	テープガイド	TAPE GUIDE	
50-10-5	105288001	1	シメネジ2.38	SCREW, SM2.38	
50-10-6	S19259001	1	オサエB	PRESSER FOOT, B	
50-10-7	140530002	1	シメネジ2.38	SCREW, SM2.38	
			<M560,W560>		
50-11	※	1	オサエクミ	PRESSER FOOT ASSY	
50-11-1	※	1	ツメ	STITCH TONGUE	
50-11-2	S19496001	1	オサエトリツケイタ	PRESSER FOOT PLATE	
50-11-3	150755001	1	シメネジ3.18	SCREW, SM3.18	
50-11-4	S19279001	1	オサエF	PRESSER FOOT, F	
50-11-5	S19300001	1	テープガイド	TAPE GUIDE	
50-11-6	062630612	1	ナベコ238-56X6	SCREW, PAN SM2.38-56X6	
50-11-7	S19299001	1	オサエB	PRESSER FOOT, B	
50-11-8	140530002	1	シメネジ2.38	SCREW, SM2.38	
50-11-9	026260136	1	ヒラザガネコガタ2.6	WASHER, PLAIN S 2.6	
			<W820>		
50-18	※	1	オサエクミ	PRESSER FOOT ASSY	
50-18-1	※	1	ツメ	STITCH TONGUE	
50-18-2	S19496001	1	オサエトリツケイタ	PRESSER FOOT PLATE	
50-18-3	150755001	1	シメネジ3.18	SCREW, SM3.18	
50-18-4	S19279001	1	オサエF	PRESSER FOOT, F	
50-18-5	060630412	1	バインド238-56X4	SCREW, BIND SM2.38-56X4	
			<M060,W060,W070,W870>		
50-2	※	1	オサエクミ	PRESSER FOOT ASSY	
50-2-1	※	1	ツメ	STITCH TONGUE	
50-2-2	S19496001	1	オサエトリツケイタ	PRESSER FOOT PLATE	
50-2-3	150755001	1	シメネジ3.18	SCREW, SM3.18	
50-2-4	S19259001	1	オサエB	PRESSER FOOT, B	
50-2-5	140530002	1	シメネジ2.38	SCREW, SM2.38	

D. 押工関係 / Presser foot mechanism

M620
W620

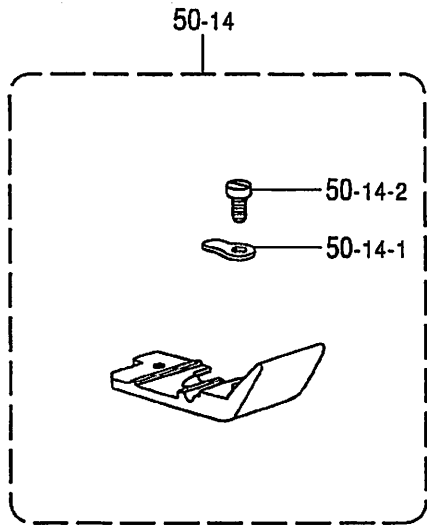

M040
W040

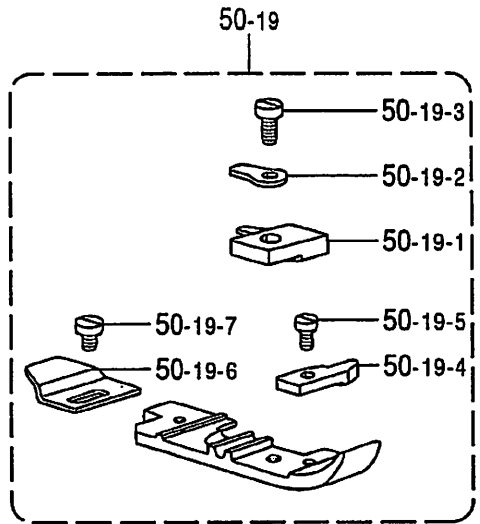

W050

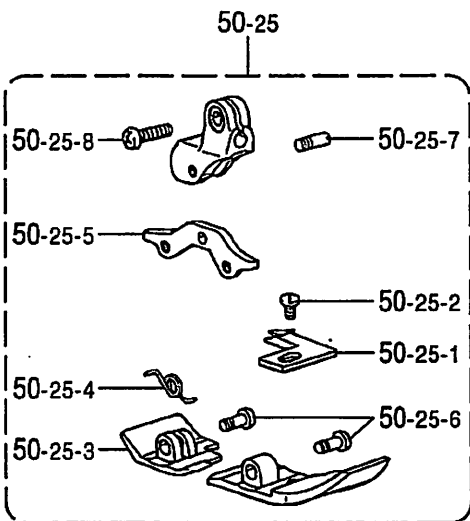

W0S0-25(SS)

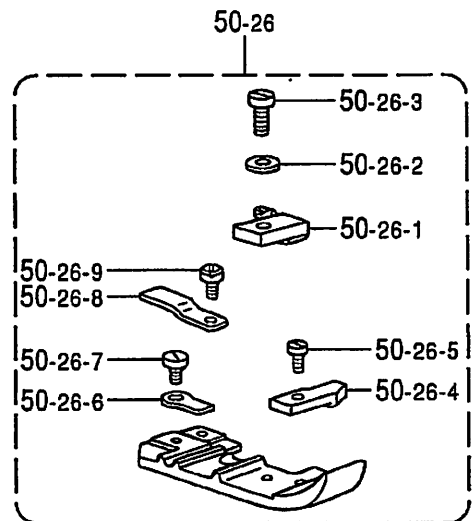

D. 押工関係 / Presser foot mechanism

REF.NO.	CODE	Q'TY	ヒンメイ	NAME OF PARTS	RM
50-14	※	1	<M620,W620> オサエクミ	PRESSER FOOT ASSY	
50-14-1	S19496001	1	オサエトリツケイタ	PRESSER FOOT PLATE	
50-14-2	106640001	1	シメネジ3.18	SCREW, SM3.18	
50-19	※	1	<M040,W040> オサエクミ	PRESSER FOOT ASSY	
50-19-1	※	1	ツメ	STITCH TONGUE	
50-19-2	S19496001	1	オサエトリツケイタ	PRESSER FOOT PLATE	
50-19-3	150755001	1	シメネジ3.18	SCREW, SM3.18	
50-19-4	S29870001	1	オサエF	PRESSER FOOT, F	
50-19-5	S01295001	1	シメネジ2.38X3.5	SCREW, SM2.38X3.5	
50-19-6	S19259001	1	オサエB	PRESSER FOOT, B	
50-19-7	140530002	1	シメネジ2.38	SCREW, SM2.38	
50-25	※	1	<W050> オサエクミ	PRESSER FOOT ASSY	
50-25-1	※	1	ツメ	STITCH TONGUE	
50-25-2	S01295001	1	シメネジ2.38X3.5	SCREW, SM2.38X3.5	
50-25-3	S30901001	1	オサエB	PRESSER FOOT, B	
50-25-4	S30902001	1	オサエBネジリバネ	PRESSER FOOT TWIST SPRING	
50-25-5	S30903001	1	オサエFBササエ	PRESSER FOOT, FB SUPPORT	
50-25-6	S30904001	2	オサエFBササエネジ	SCREW, PRESSER FOOT SUPPORT	
50-25-7	S19311101	1	オサエササエネジ	SCREW, PRESSER FOOT SUPPORT	
50-25-8	062670712	1	ナベコ357-40X7	SCREW, PAN SM3.57-40X7	
50-26	※	1	<W050-25(SS) 用> オサエクミ	PRESSER FOOT ASSY	
50-26-1	※	1	ツメ	STITCH TONGUE	
50-26-2	S20391001	1	スペーサ	SPACER	
50-26-3	150755001	1	シメネジ3.18	SCREW, SM3.18	
50-26-4	S19258001	1	オサエF	PRESSER FOOT, F	
50-26-5	S01295001	1	シメネジ2.38X3.5	SCREW, SM2.38X3.5	
50-26-6	S19496001	1	オサエトリツケイタ	PRESSER FOOT PLATE	
50-26-7	150755001	1	シメネジ3.18	SCREW, SM3.18	
50-26-8	S36869001	1	オサエB	PRESSER FOOT, B	
50-26-9	140530002	1	シメネジ2.38	SCREW, SM2.38	

E. 送り関係 / Feed mechanism

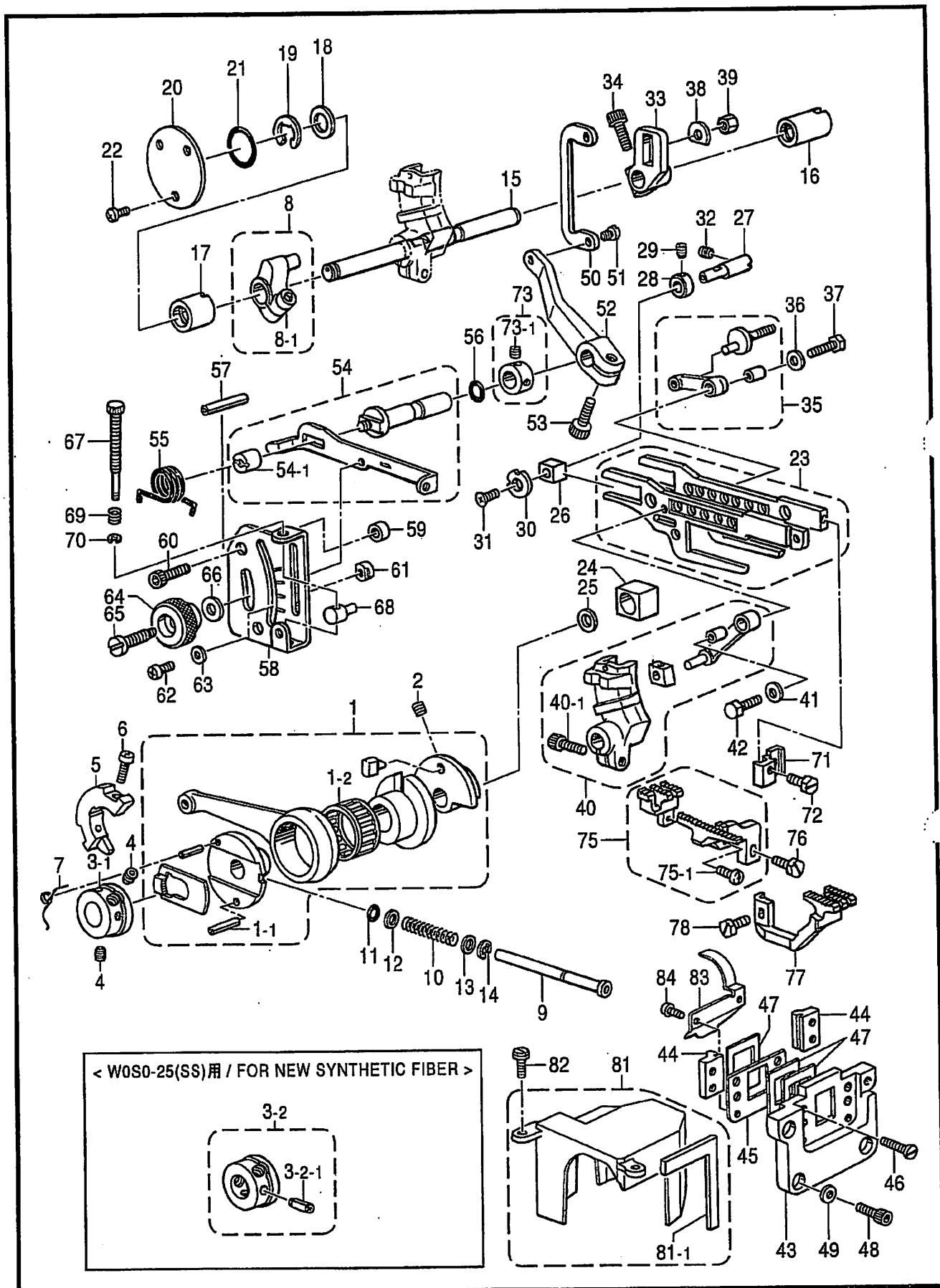

E. 送り関係 / Feed mechanism

REF.NO.	CODE	Q'TY	ヒンメイ	NAME OF PARTS	RM
1	S20496101	1	ヘンシンリンクミ	ECCENTRIC LINK ASSY.	
1-1	047250842	1	スプリングピンAW2.5	PIN, SPRING ROLL AW2.5	
1-2	S20500001	1	ニードルジクウケ24 (赤)	NEEDLE BEARING 24 RED	
1-2	S20500002	1	ニードルジクウケ24 (青)	NEEDLE BEARING 24 BLUE	
1-2	S20500003	1	ニードルジクウケ24 (白)	NEEDLE BEARING 24 WHITE	
2	012060632	2	アナヒラ6X6	SET SCREW, SOCKET (FT) M6X6	
3-1	S20507001	1	ラチエツト	RATCHET	
4	012060632	2	アナヒラ6X6	SET SCREW, SOCKET (FT) M6X6	
5	S23615001	1	バランスウエイト	BALANCE WEIGHT	
6	062401012	2	ナベコM4X10	SCREW, PAN M4X10	
7	S23458101	1	ラチエツトトメネジリバネ	SPRING, TWIST	
8	S39589021	1	オクリウデクミ	FEED ARM ASSY	
8-1	018061632	1	アナボルト6X16	BOLT, SOCKET M6X16	
9	S39674001	1	オクリチヨウセツボタンジク	FEED ADJUST SHAFT	
10	S39675001	1	ボタンジクバネ	SPRING	
11	081005070	1	OリングP5	O RING, P5	
12	025710232	1	ヒラザガネチユウ4.76	WASHER, PLAIN M 4.76	
13	025710232	1	ヒラザガネチユウ4.76	WASHER, PLAIN M 4.76	
14	048040342	1	トメワE4	RETAINING RING, E4	
15	S39676121	1	オクリジク	FEED SHAFT	
16	S39677021	1	メタル11.11-17	BUSH, 11.11-17	
17	S39678021	1	オクリジクメタルL	FEED SHAFT BUSH, L	
18	S30562000	1	ザガネ	WASHER	
19	048090342	1	トメワE9	RETAINING RING, E9	
20	S39679001	1	オクリジクメタルLフタ	FEED SHAFT BUSH CAP, L	
21	081020070	1	OリングP20	O RING, P20	
22	060400612	3	バインドM4X6	SCREW, BIND M4X6	
23	S46891001	1	オクリダイクミ	FEED BAR ASSY	
24	S38312050	1	ジヨウゲオクリカクゴマ	FEED LIFTING SLIDE BLOCK	
25	142628001	2	スイハイオクリクランクリング	FEED ROCK CRANK RING	
26	S39683000	1	オクリダイカクゴマ	FEED BAR SLIDE BLOCK	
27	S39684021	1	オクリダイカクコマジク	FEED BAR SLIDE BLOCK SHAFT	
28	S39685001	1	セツトカラー	SET SCREW COLLAR	
29	012400432	1	アナヒラ4X4	SET SCREW, SOCKET (FT) M4X4	
30	S20530001	1	ザガネ	WASHER	
31	004350812	1	+サラコ35X8	SCREW, FLAT M3.5X8	
32	012400832	1	アナヒラ4X8	SET SCREW, SOCKET (FT) M4X8	
33	S42042021	1	シユオクリウデ	MAIN FEED ARM	
34	018061632	1	アナボルト6X16	BOLT, SOCKET M6X16	
35	S39773001	1	シユオクリリンククミ	MAIN FEED LINK ASSY	
36	S39690021	1	ザガネ	WASHER	
37	S23360001	1	ボルト5X15	BOLT, M5X15	
38	S02573000	1	ザガネ	WASHER	
39	S39691001	1	ナツト5	NUT, M5	
40	S39769051	1	サドウオクリウデリンククミ	DIFF. FEED ARM LINK ASSY	
40-1	018061632	1	アナボルト6X16	BOLT, SOCKET M6X16	
41	S39690021	1	ザガネ	WASHER	
42	S23360001	1	ボルト5X15	BOLT, M5X15	
43	S20523000	1	オクリダイアンナイササエ	FEED BAR GUIDE SUPPORT	
44	S20524000	2	オクリダイアンナイ	FEED BAR GUIDE	
45	S20525001	1	ボウジンイタササエ	FRAGMENT PROTECTOR PLATE	
46	S20740101	4	シメネジ4X10シール	SCREW, SEAL M4X10	
47	S20526000	3	ボウジンイタ	FRAGMENT PROTECTOR PLATE	
48	S43916001	4	アナボルト4X8シール	SCREW, SEAL M4X10	
49	025040132	4	ヒラザガネシヨウ4	WASHER, PLAIN S 4	
50	S39692021	1	サドウチヨウセツリンク	DIFFERENTIAL FEED ADJUST LINK	
51	S20543101	1	シメネジ5	SCREW, M5	
52	S20544000	1	サドウリンクレバー	DIFFERENTIAL LINK LEVER	
53	018061432	1	アナボルト6X14	BOLT, SOCKET M6X14	

E. 送り関係 / Feed mechanism

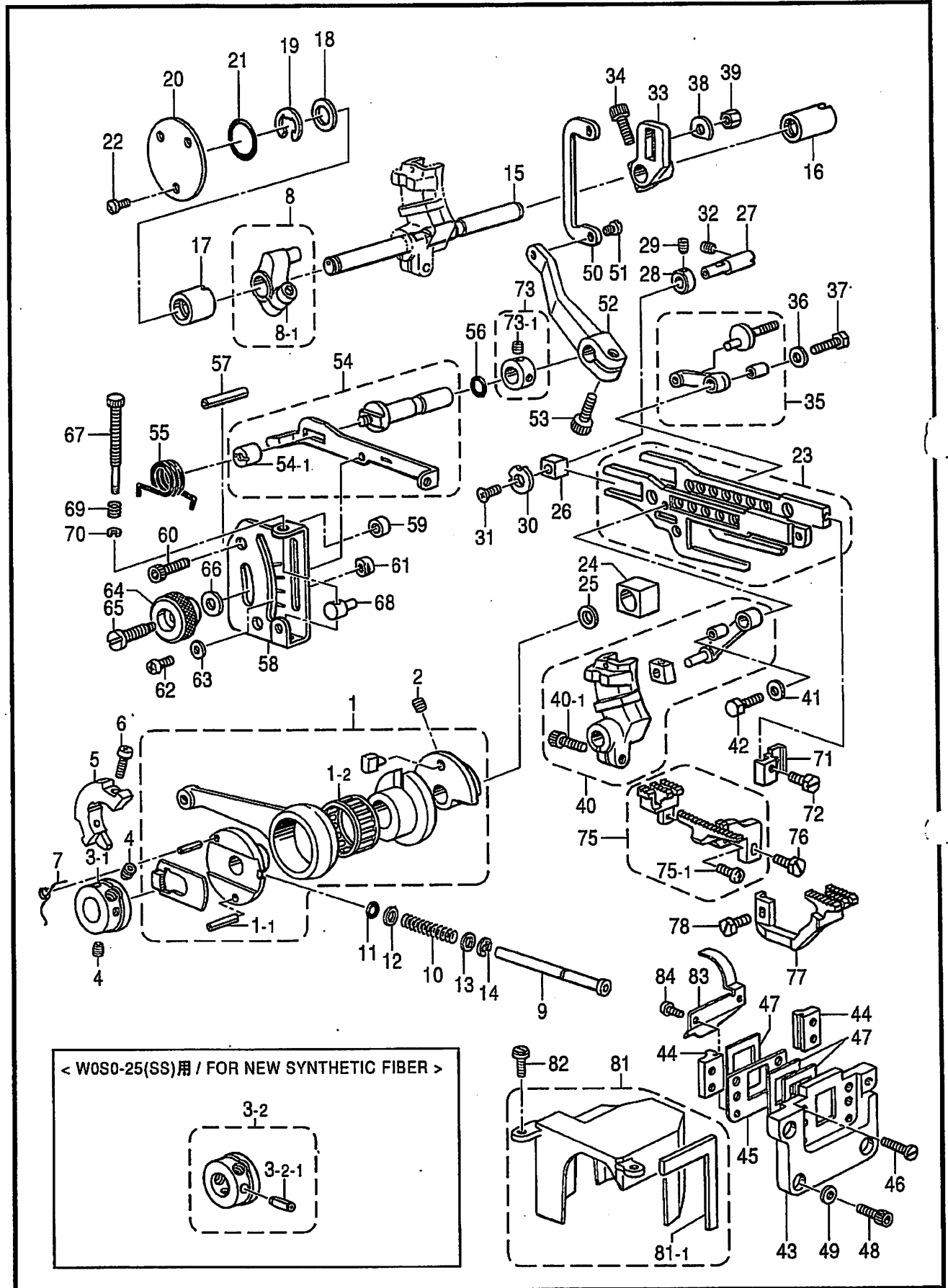

E. 送り関係 / Feed mechanism

REF.NO.	CODE	Q'TY	ヒンメイ	NAME OF PARTS	RM
54	S39593021	1	サドウチヨウセツレバークミ	DIFF. FEED ADJUST LEVER ASSY	
54-1	S39596021	1	マルナツト6	NUT, ROUND M6	
55	S20547001	1	レバーバネ	SPRING	
56	081005670	1	OリングPW5	O RING, PW5	
57	047502542	1	スプリングピンAW5	PIN, SPRING ROLL AW5	
58	S20554001	1	サドウリヨウメモリイタ	DIFFERENTIAL STITCH CONTROL PLATE	
59	S20548001	2	カラー	COLLAR	
60	018061632	2	アナボルト6X16	BOLT, SOCKET M6X16	
61	S25818001	2	チヨウセツレバーストツバ	STOPPER FOR ADJUST LEVER	
62	060350812	2	バインド35X8	SCREW, BIND M3.5X8	
63	025350332	2	ヒラザガネダイ3.5	WASHER, PLAIN L 3.5	
64	S39694021	1	セツトネジツマミ	SET SCREW KNOB	
65	S39695001	1	セツトネジ	SET SCREW	
66	S20560001	1	サラバネザガネ	SPRING WASHER	
67	S20561001	1	マイクロチヨウセツネジ	MICRO ADJUST SCREW	
68	S46895001	1	マイクロチヨウセツストツバ	STOPPER, MICRO ADJUST.	
69	S29094001	1	マイクロチヨウセツネジバネ	MICRO ADJUST SPRING	
70	048040342	1	トメワE4	RETAINING RING, E4	
71	S23628051	1	シユオクリバトリツケダイ	FEED DOG SETTING BASE	
72	S23621101	1	ボルト35X8	BOLT, M3.5X8	
73	S23612001	1	セツトカラークミ	SET SCREW COLLAR ASSY	
73-1	012060632	2	アナヒラ6X6	SET SCREW, SOCKET (FT) M6X6	
75	※	1	シユオクリバクミ	MAIN FEED DOG ASSY	
75-1	060630712	1	バインド238-56X7	SCREW, BIND SM2.38-56X7	
76	S23621101	1	ボルト35X8	BOLT, M3.5X8	
77	※	1	サドウオクリバ	DIFFERENTIAL FEED DOG	
78	S23621101	1	ボルト35X8	BOLT, M3.5X8	
81	S21091000	1	ヘンシンリンカバークミ	ECCENTRIC WHEEL COVER ASSY	
81-1	S21092000	1	カバースポンジ	COVER SPONGE	
82	S23616101	2	シメネジ4X10	SCREW, M4X10	
83	S20527001	1	アブラキリイタ	OIL REJECTOR PLATE	
84	S23453001	2	ナベコ3X5シール	SCREW 3X5 SEAL	
			<55用>	< FOR NEW SYNTHETIC FIBER >	
3-2	S36864001	1	ラチェットクミ	RATCHET ASSY	
3-2-1	047301042	1	スプリングピン	PIN, SPRING ROLL AW3	

G. 上メス・下メス関係 / Knife mechanism

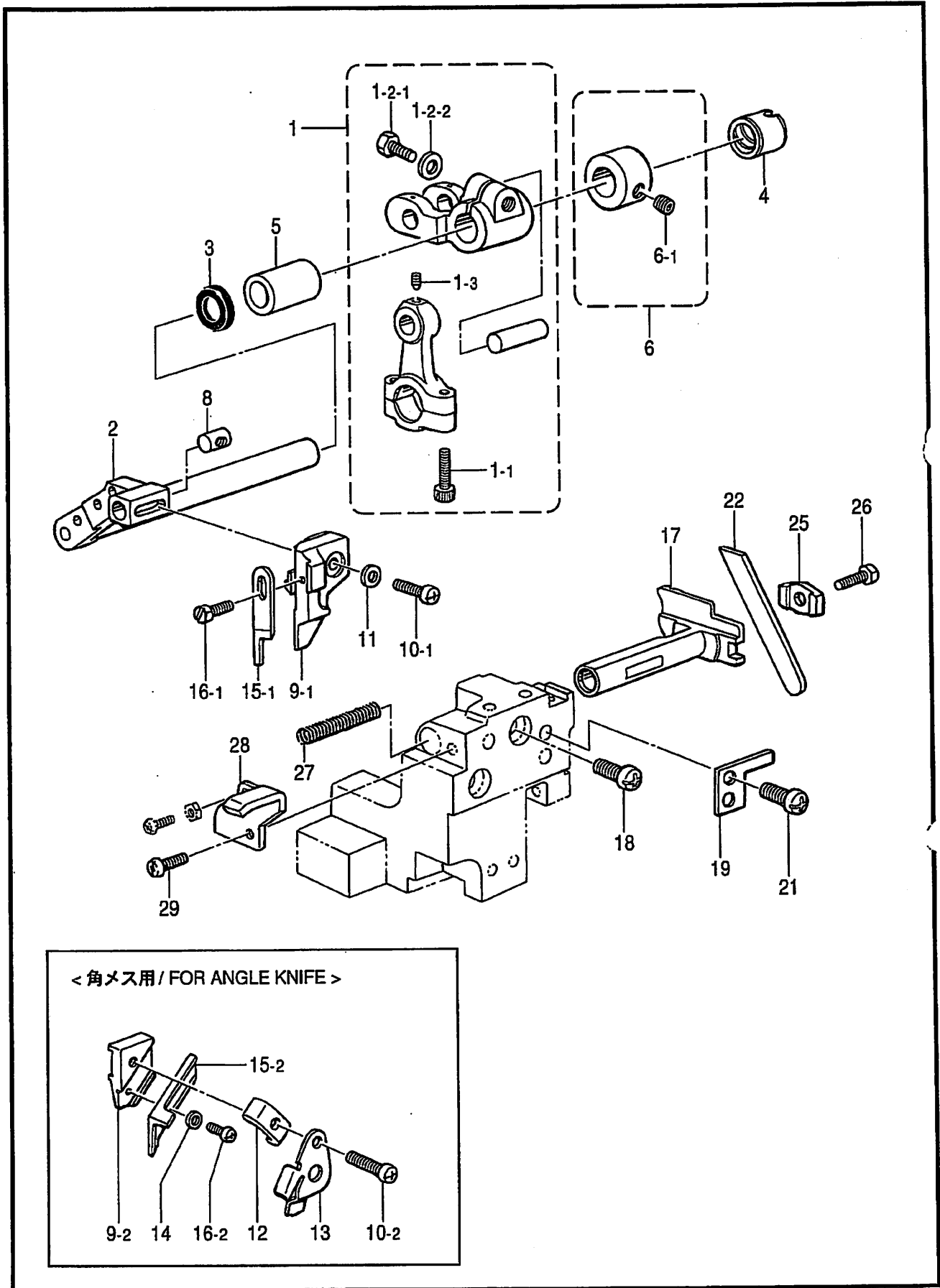

G. 上メス・下メス関係 / Knife mechanism

REF.NO.	CODE	QTY	ヒンメイ	NAME OF PARTS	RM
1	S46933001	1	ウワメスクランクロツドクミO	UPPER KNIFE CRANK ROD ASSY, O	
1-1	018401622	2	アナボルト4X16	BOLT, SOCKET M4X16	
1-2-1	017061612	1	ボルト6X16	BOLT, M6X16	
1-2-2	118735002	1	ザガネ	WASHER	
1-3	S23342001	1	アナトガリ4X5	SET SCREW, SOCKET (CN) M4X5	
2	S20571101	1	ウワメスサドウウデ	UPPER KNIFE DIFFERENTIAL ARM	
3	155247000	1	ダストシール	DUST SEAL	
4	S39704021	1	ウワメスメタルL	UPPER KNIFE BUSH L	
5	S39677021	1	メタル11.11-17	BUSH, 11.11-17	
6	S23619001	1	セツトカラークミ	SET SCREW COLLAR ASSY	
6-1	012060632	2	アナヒラ6X6	SET SCREW, SOCKET (FT) M6X6	
8	S20574001	1	ウワメスダキナツト	NUT	
17	S20580101	1	シタメストリツケダイ	LOWER KNIFE HOLDER	
18	062060812	1	ナベコ6X8	SCREW, PAN M6X8	
19	S39707001	1	シタメストリツケダイアンナイ	LOWER KNIFE HOLDER GUIDE	
21	062060812	2	ナベコ6X8	SCREW, PAN M6X8	
22	※	1	シタメス	LOWER KNIFE	
25	S39708001	1	シタメスオサエ	LOWER KNIFE PRESSER	
26	017500812	1	ボルト5X8	BOLT, M5X8	
27	S20585001	1	シタメストリツケダイバネ	SPRING	
28	S39709021	1	シタメスバネウケ	SPRING HOLDER	
29	060400812	1	バインドM4X8	SCREW, BIND M4X8	
			<平メス用部品>	<FOR PLAIN KNIFE>	
9-1	S20575001	1	ウワメスダキ	UPPER KNIFE HOLDER	
10-1	062401212	1	ナベコ4X12	SCREW, PAN M4X12	
11	025040132	1	ヒラザガネシヨウ4	WASHER, PLAIN S 4	
15-1	144074350	1	ウワメス	UPPER KNIFE	
16-1	S23621101	1	ボルト35X8	BOLT, M3.5X8	
			<角メス用部品>	<FOR ANGLE KNIFE>	
9-2	S20576001	1	ウワメスダキ	UPPER KNIFE HOLDER	
10-2	062401612	1	ナベコM4X16	SCREW, PAN M4X16	
12	S20577001	1	ウワメスオサエ	UPPER KNIFE PRESSER	
13	S20578101	1	ウワメスオサエイタ	UPPER KNIFE PRESSER PLATE	
14	025030132	1	ヒラザガネシヨウ3	WASHER, PLAIN S 3	
15-2	S20897101	1	カクメス 幅狭 波刃	ANGLE KNIFE, NARROW WAVE EDGE	
16-2	062300412	1	ナベコ3X4	SCREW, PAN M3X4	
			<オプションパーツ>	<OPTION PARTS>	
15-2	S20896101	1	カクメス 幅狭	ANGLE KNIFE, NARROW	
15-2	S20579101	1	カクメス 幅広	ANGLE KNIFE, WIDE	
15-2	S20898101	1	カクメス 幅広 波刃	ANGLE KNIFE, WIDE WAVE EDGE	

H. 上ルーパ関係 / Over looper mechanism

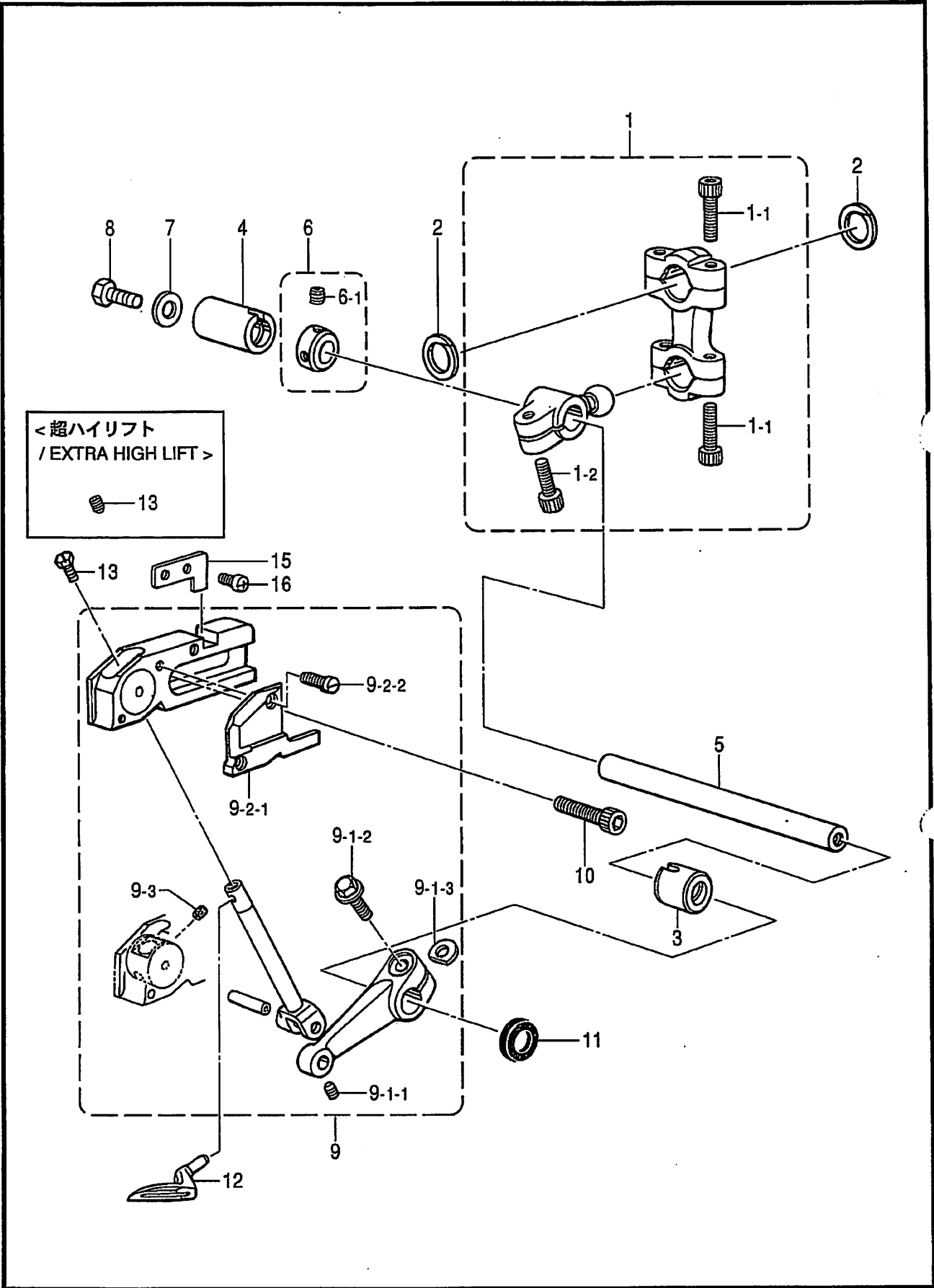

H. 上ルーパ関係 / Over looper mechanism

REF.NO.	CODE	Q'TY	ヒンメイ	NAME OF PARTS	RM
1	S46940001	1	ウワルーパロッドクミHE	OVER LOOPER ROD ASSY, S	
1-1	018401622	4	アナボルト4X16	BOLT, SOCKET M4X16	
1-2	S23346101	1	アナホルト6X14ホソメ	BOLT, SOCKET M6X14	
2	S20598000	2	ロッドフレドメ	ROD STOPPER	
3	S39728021	1	メタル11.11-18	BUSH, 11.11-18	
4	S39677021	1	メタル11.11-17	BUSH, 11.11-17	
5	S20601001	1	ウワルーパジク	OVER LOOPER SHAFT	
6	S23619001	1	セットカラークミ	SET SCREW COLLAR ASSY	
6-1	012060632	2	アナヒラ6X6	SET SCREW, SOCKET (FT) M6X6	
7	S23626001	1	ザガネ	WASHER	
8	017060812	1	ボルト6X8	BOLT, M6X8	
				<FOR HIGH LIFT>	
9	S46896001	1	ウワルーパキコウクミSH	OVER LOOPER ROD ASSY, SH	
13	S46903001	1	アタマツキトメネジ4X5	SET SCREW, M4X5	
				<FOR EXTRA HIGH LIFT>	
9	S46901001	1	ウワルーパキコウクミE	OVER LOOPER MECHANISM ASSY, E	
13	012400432	1	アナヒラ4X4	SET SCREW, SOCKET (FT) M4X4	
9-1-1	S23342001	1	アチトガリ4X5	SET SCREW, SOCKET (CN) M4X5	
9-1-2	S46899001	1	ザガネツキボルト6X16	BOLT, (S/P WASHER) M6X16	
9-1-3	155162001	1	スペーサ	SPACER	
9-2-1	S38320100	1	ウワルーパアンナイオサエ	SPACER	
9-2-2	S20355002	2	シメネジ3X8.5	SCREW, M3X8.5	
9-3	S29700000	2	ウワルーパアンナイフェルト	OVER LOOPER GUIDE FELT	
10	018061432	2	アナホルト6X14	BOLT, SOCKET M6X14	
11	155247000	1	ダストシール	DUST SEAL	
12	※	1	ウワルーパ	OVER LOOPER, B	
15	S23611101	1	アンナイメタルイチギメイタ	POTISIONING PLATE, GUIDE BUSH	
16	060400612	2	バインドM4X6	SCREW, BIND M4X6	

J. 下ルーパ関係 / Under looper mechanism.

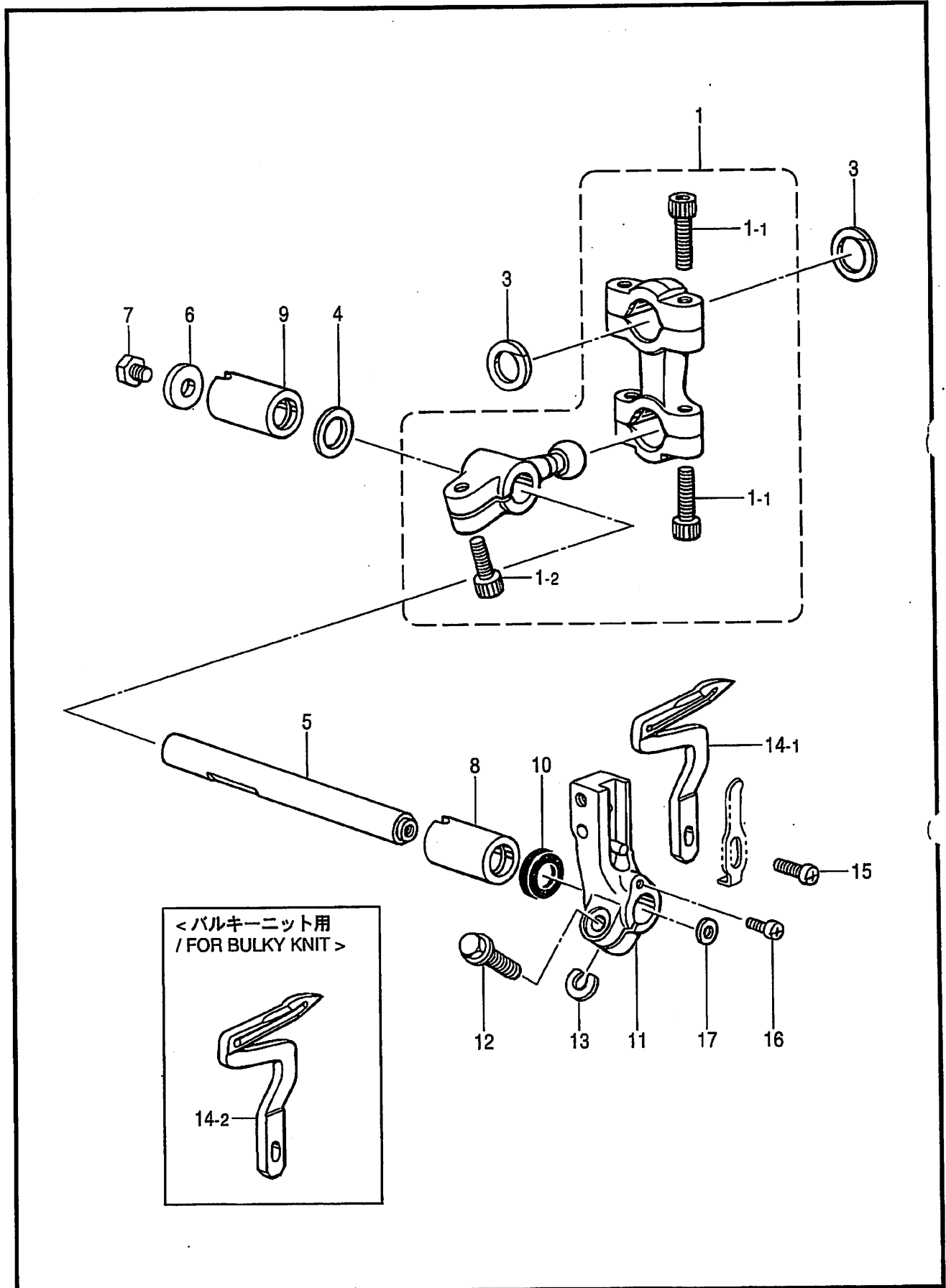

J. 下ルーパ関係 / Under looper mechanism

REF.NO.	CODE	Q'TY	ヒンメイ	NAME OF PARTS	RM
1	S46941001	1	<ハイリフト用> シタルーパロッドクミOSH	<FOR HIGH LIFT> UNDER LOOPER ROD ASSY, O-SH	
1	S46942001	1	<超ハイリフト用> シタルーパロッドクミOE	<FOR EXTRA HIGH LIFT> UNDER LOOPER ROD ASSY, O-E	
1-1	018401622	4	アナボルト4X16	BOLT, SOCKET M4X16	
1-2	S23346101	1	アナボルト6X14ホソメ	BOLT, SOCKET M6X14	
3	S20598000	2	ロッドフレドメ	ROD STOPPER	
4	S20621001	1	カラー	COLLAR	
5	S46904001	1	シタルーパジク	UNDER LOOPER SHAFT	
6	S23626001	1	ザガネ	WASHER	
7	017060812	1	ボルト6X8	BOLT, M6X8	
8	S39728021	1	メタル11.11-18	BUSH, 11.11-18	
9	S39677021	1	メタル11.11-17	BUSH, 11.11-17	
10	155247000	1	ダストシール	DUST SEAL	
11	S20625151	1	シタルーパトリツケダイ	UNDER LOOPER HOLDER	
12	S23614101	1	フランジボルト5X14	BOLT, M5X14	
13	148782001	1	スペーサ	SPACER	
14-1	S20627001	1	シタルーパ	UNDER LOOPER	
15	060351012	1	バインド3.5X10	SCREW, BIND M3.5X10	
16	060350812	1	バインド3.5X8	SCREW, BIND M3.5X8	
17	158722002	1	ザガネ4.2	WASHER, PLAIN 4.2	
14-2	S40866001	1	<バルキーニット用> シタルーパ	<FOR BULKY KNIT> UNDER LOOPER	

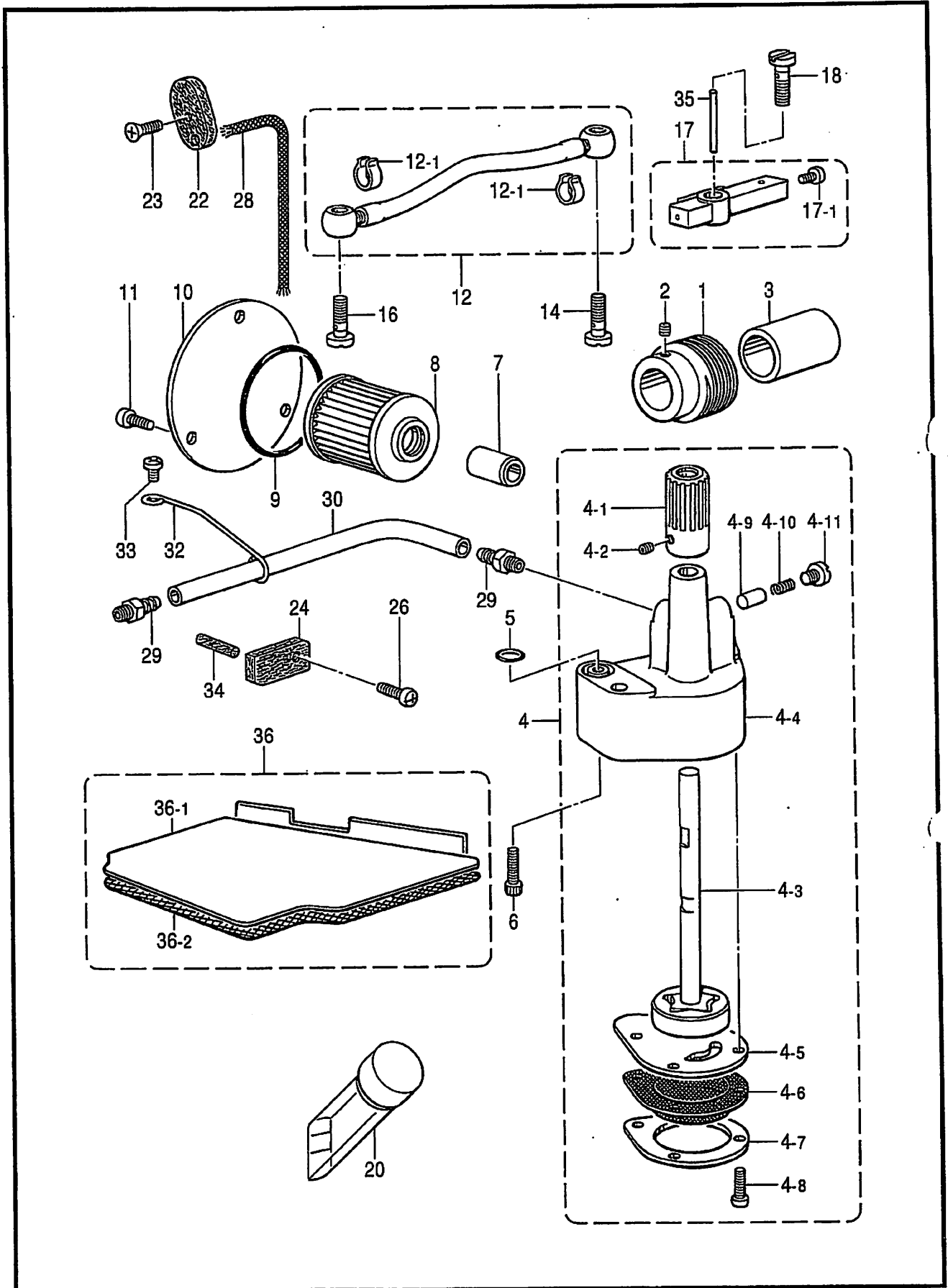

L. 給油潤滑関係 / Lubrication

REF.NO.	CODE	Q'TY	ヒンメイ	NAME OF PARTS	RM
1	S20655101	1	ウオーム	WORM	
2	012500536	2	アナヒラ5X5	SET SCREW, SOCKET (FT) M5X5	
3	S23366001	1	カラー	COLLAR	
4	S20656101	1	トロコイドポンプクミ	PUMP ASSY	
4-1	S20657001	1	ウオームホイール	WORM WHEEL	
4-2	012400536	2	アナヒラ4X5	SET SCREW, SOCKET (FT) M4X5	
4-3	S20658001	1	ポンプロータークミ	PUMP INNER ROTER ASSY	
4-4	S20660000	1	ポンプケース	PUMP CASE	
4-5	S20661000	1	ポンプタイフタ	CAP, PUMP BODY	
4-6	S20662100	1	ロカモウ	OIL FILTER	
4-7	S20663000	1	ロカモウオサエ	FILTER SUPPORT	
4-8	062351016	4	ナベコ3.5X10	SCREW, PAN M3.5X10	
4-9	144875001	1	プランジャー	PLUNGER	
4-10	144876001	1	プランジャーバネ	SPRING	
4-11	S23460001	1	ナベコ6X5	SCREW, PAN M6X5	
5	081008070	1	OリングP8	O RING, P8	
6	018061432	2	アナホルト6X14	BOLT, SOCKET M6X14	
7	S08957001	1	オイルクチ	OIL FEEDING PIPE	
8	S08956100	1	オイルフィルター	OIL FILTER	
9	081044070	1	OリングP44	O RING, P44	
10	S12987002	1	オイルフィルターフタ	CAP, OIL FILTER	
11	060400812	3	バインドM4X8	SCREW, BIND M4X8	
12	S46905001	1	ビニルチューブクミ	OIL TUBE ASSY	
12-1	147942001	2	ビニルチューブトメガネ	STOP RING	
14	S20199001	1	ハイユパイプツギテ	OIL PIPE JOINT	
16	S20199001	1	ハイユパイプツギテ	OIL PIPE JOINT	
17	S20666001	1	キユウユパイプクミ	OIL PIPE ASSY	
17-1	060400512	1	バインドM4X5	SCREW, BIND M4X5	
18	S20199001	1	ハイユパイプツギテ	OIL PIPE JOINT	
20	148084001	1	オイルゲージマド	OIL GAUGE WINDOW	
22	S20668100	1	ハリボウリンクフェルト	NEEDLE BAR LINK FELT	
23	061400812	1	サラコM4X8	SCREW, FLAT M4X8	
24	S20669000	1	フェルト	FELT	
26	060400812	1	バインドM4X8	SCREW, BIND M4X8	
28	S20671000	1	クミヒモ100	WICK (L = 100)	
29	S20180001	2	オイルクチ	OIL FEEDING PIPE	
30	S20200001	1	ビニルチューブ	OIL TUBE (L = 370)	
32	S25879001	1	チューブササエ	TUBE SUPPORT	
33	060400812	1	バインドM4X8	SCREW, BIND M4X8	
34	S20392000	1	フェルト	FELT	
35	S25526000	1	ピン	PIN	
36	S43523000	1	フィルタークミ	FILTER ASSY	
36-1	S43522000	1	オイルフィルター	OIL FILTER	
36-2	S43521000	1	ロカモウD	FILTER, D	

M . 糸調子關係 / Thread tension

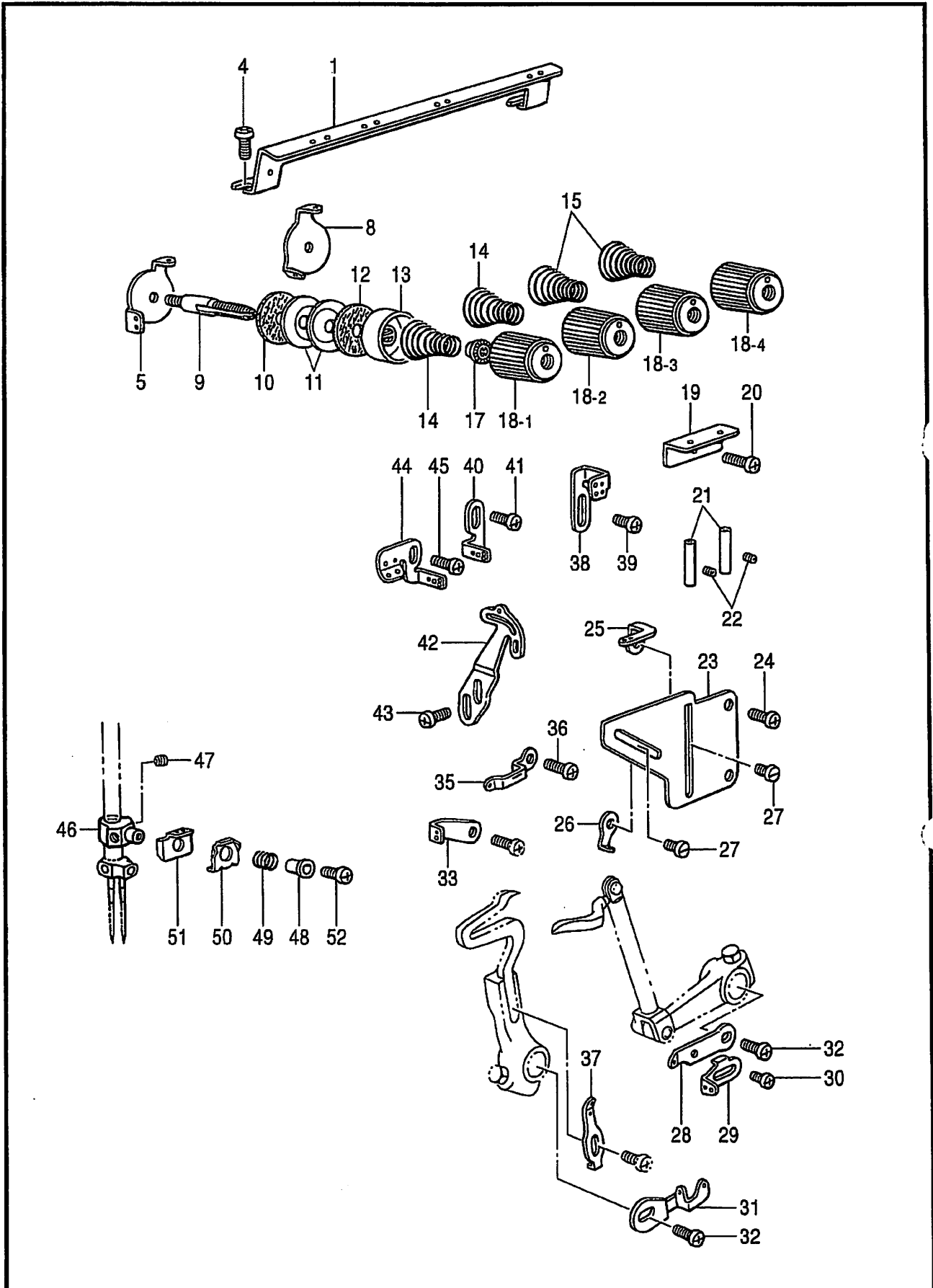

M.糸調子関係 / Thread tension

REF.NO.	CODE	Q'TY	品名	NAME OF PARTS	RM
1	S20672001	1	シユイトアンナイ	MAIN THREAD GUIDE	
4	060400812	2	バインドM4X8	SCREW, BIND M4X8	
5	S20693001	1	ハライトアンナイ2N	NEEDLE GUIDE (2N)	
8	S20675001	3	チヨウシサライトアンナイ	TENSION DISC THREAD GUIDE	
9	S20676051	4	イトチヨウシボウ	TENSION STUD	
10	S20677000	4	イトチヨウシサラフェルト	TENSION DISC FELT	
11	S20673001	8	イトチヨウシサラ	TENSION DISC	
12	110832009	4	イトチヨウシサラフェルト	TENSION DISC FELT	
13	144103009	4	イトチヨウシサラオサエ	TENSION DISC PRESSER	
14	S20678001	2	イトチヨウシバネL	TENSION SPRING, L	
15	S20679001	2	イトチヨウシバネM	TENSION SPRING, M	
17	S20681000	4	チヨウシバネウエザガネ	WASHER	
18-1	S20682103	1	イトチヨウシナツト(赤)	TENSION NUT, RED	
18-2	S20682101	1	イトチヨウシナツト(水色)	TENSION NUT, LIGHT BLUE	
18-3	S20682104	1	イトチヨウシナツト(黄)	TENSION NUT, YELLOW	
18-4	S20682102	1	イトチヨウシナツト(緑)	TENSION NUT, GREEN	
19	S20683001	1	ルーバイトアンナイ	LOOPER THREAD GUIDE	
20	060400812	1	バインドM4X8	SCREW, BIND M4X8	
21	146592001	2	イトアンナイパイプ	THREAD GUIDE PIPE	
22	S23452002	2	アナヒラ4X3.2	SET SCREW, SOCKET (FT) M4X3.2	
23	S20684101	1	イトアンナイドダイ	THREAD GUIDE BRACKET	
24	060400612	2	バインドM4X6	SCREW, BIND M4X6	
25	S20685001	1	シタルーバイトアンナイR	UNDER LOOPER THREAD GUIDE, R	
26	S20686001	1	ウワルーバイトアンナイR	OVER LOOPER THREAD GUIDE, R	
27	S23418002	2	シメネジ4X5	SCREW, M4X5	
28	S21133001	1	ウワルーパテンビンR	OVER LOOPER THREAD TAKE-UP, R	
29	S21134001	1	シタルーパテンビンR	UNDER LOOPER THREAD TAKE-UP, R	
30	060300412	1	バインドM3X4	SCREW, BIND M3X4	
31	S21135001	1	ルーパテンビンL	LOOPER THREAD TAKE-UP, L	
32	060400612	2	バインドM4X6	SCREW, BIND M4X6	
33	S21137001	1	ルーバイトアンナイM1	LOOPER THREAD GUIDE, M1	
35	S21136101	1	ウワルーバイトアンナイL	OVER LOOPER THREAD GUIDE, L	
36	060400612	1	バインドM4X6	SCREW, BIND M4X6	
37	S20687001	1	シタルーバイトアンナイL	UNDER LOOPER THREAD GUIDE, L	
38	S21127001	1	ハライトアンナイC	NEEDLE THREAD GUIDE (C)	
39	060400612	1	バインドM4X6	SCREW, BIND M4X6	
40	S21129001	1	ハライトアンナイB	NEEDLE THREAD GUIDE, B	
41	060400612	1	バインドM4X6	SCREW, BIND M4X6	
42	S21130051	1	ハライトテンピンA	NEEDLE THREAD TAKE-UP, A	
43	060400812	2	バインドM4X8	SCREW, BIND M4X8	
44	S21128001	1	ハライトアンナイA	NEEDLE THREAD GUIDE, A	
45	060400612	1	バインドM4X6	SCREW, BIND M4X6	
46	S38330050	1	ハライトオサエホルダー	NEEDLE THREAD PRESSER HOLDER	
47	146427001	2	アナトメネジ3.18クボミ	SET SCREW, SOCKET (CP) SM3.18	
48	S20689001	1	ハライトオサエカラー	NEEDLE THREAD PRESSER COLLAR	
49	S20690001	1	ハライトオサエバネ	SPRING	
50	S20691001	1	ハライトオサエイタ	NEEDLE THREAD PRESSER PLATE	
51	S20692001	1	ハライトアンナイ	NEEDLE THREAD GUIDE	
52	060300612	1	バインドM3X6	SCREW, BIND M3X6	

P . 針冷却関係 / Needle cooler

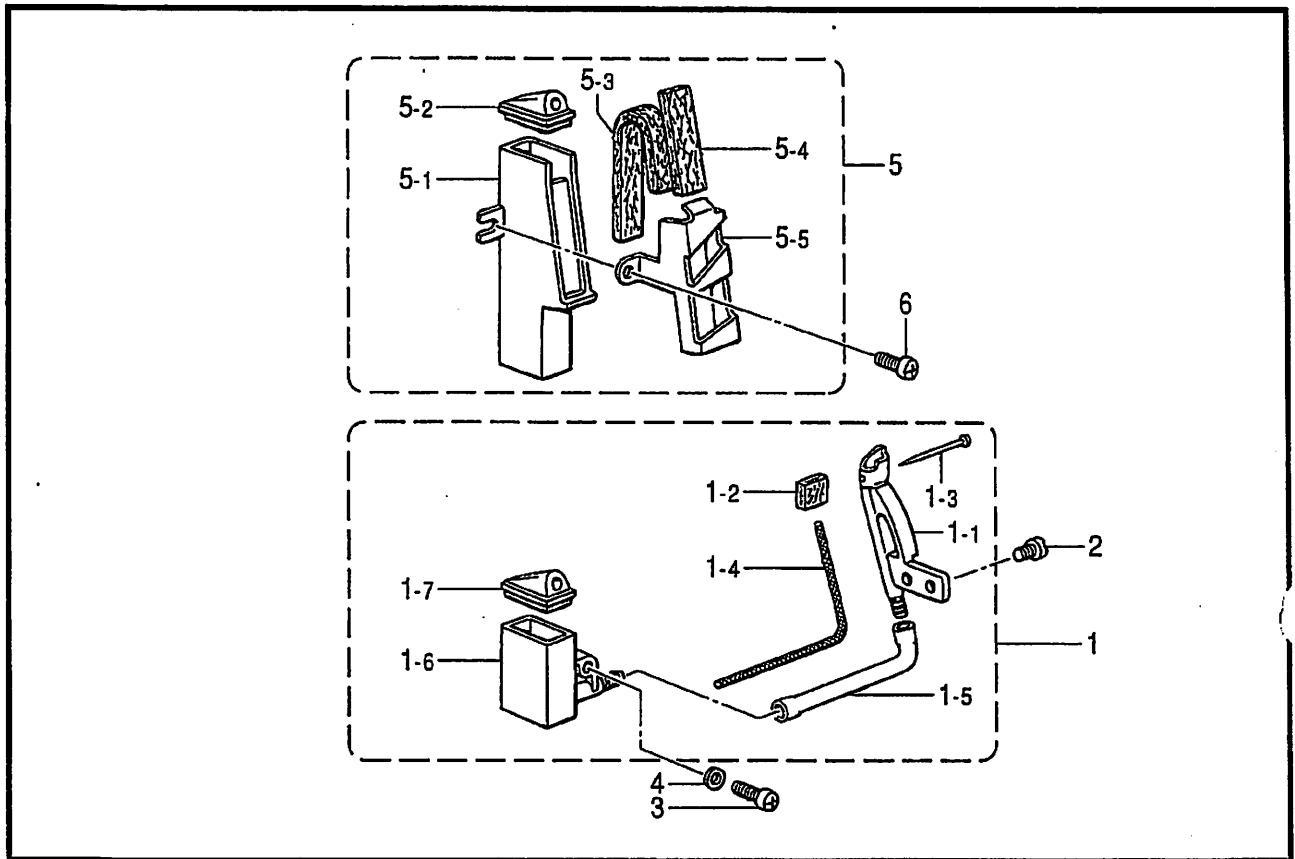

878-V5A-124

Q . 縁カガリ定規関係 / Serging attachment

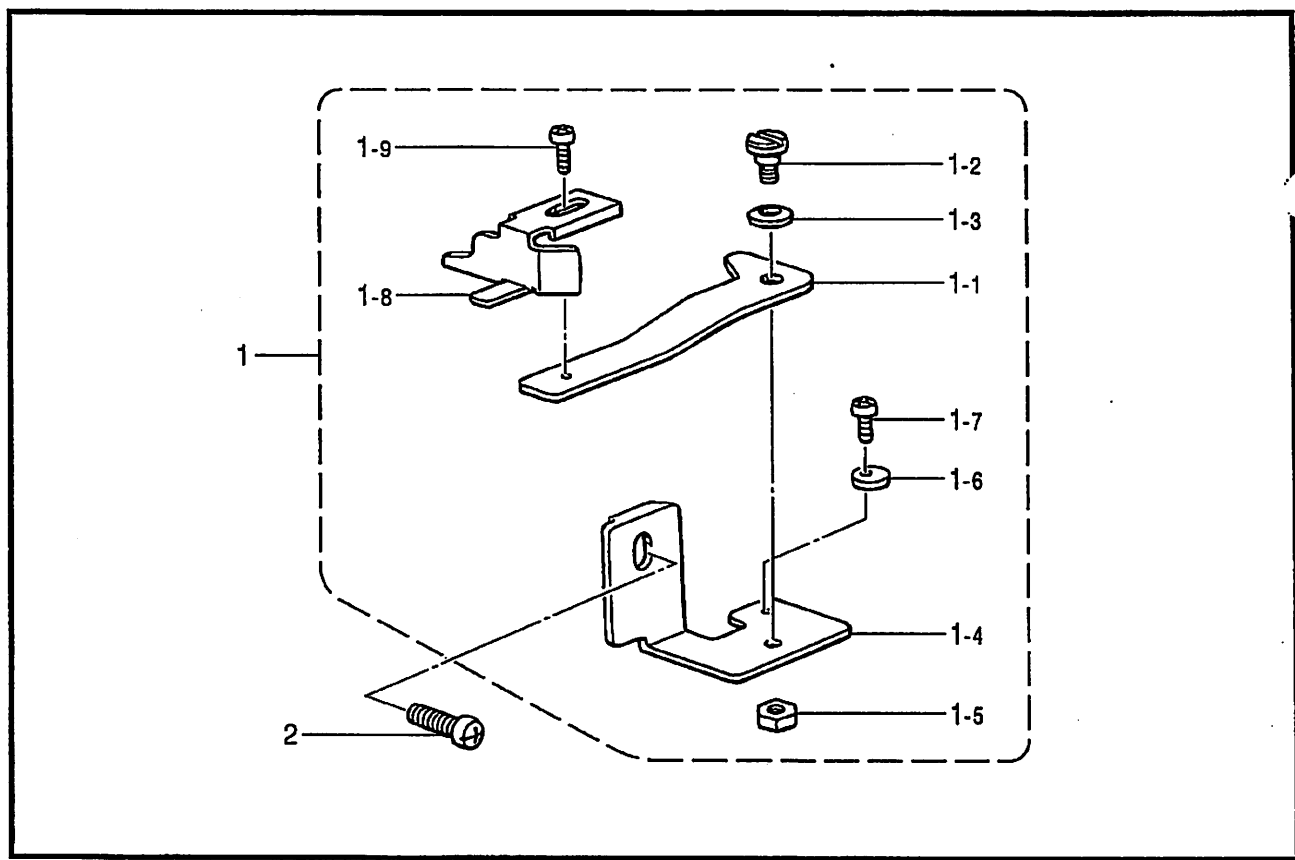

P. 針冷却関係 / Needle cooler

REF.NO.	CODE	Q'TY	ヒンメイ	NAME OF PARTS	RM
1	S20453001	1	フェルトササエクミ	FELT SUPPORT ASSY	
1-1	S20454000	1	フェルトササエ	FELT SUPPORT	
1-2	S20455000	1	フェルト	FELT	
1-3	S02874001	1	ムシピン	PIN	
1-4	150307000	1	クミヒモ	WICK (L= 140)	
1-5	S20456000	1	ビニルチューブ55	VINYL TUBE 55	
1-6	S20459000	1	シリコンタンクタイL	SILICONE TANK (L)	
1-7	S20460000	1	シリコンタンクフタ	SILICONE TANK CAP	
2	S23418002	2	シメネジ4X5	SCREW, M4X5	
3	060401012	1	バインドM4X10	SCREW, BIND M4X10	
4	025040132	1	ヒラザガネシヨウ4	WASHER, PLAIN 5 4	
5	S20461101	1	シリコンタンククミU	SILICONE TANK ASSY (U)	
5-1	S20464000	1	シリコンタンクU	SILICONE TANK (U)	
5-2	S20460000	1	シリコンタンクフタ	SILICONE TANK CAP	
5-3	S29933000	1	フェルトL	FELT (L)	
5-4	S29934000	1	フェルトS	FELT (S)	
5-5	S20467001	1	フェルトオサエイタ	FELT SUPPORT PLATE	
6	062401012	1	ナベコM4X10	SCREW, PAN M4X10	

878-V5A-124

Q. 縁カガリ定規関係 / Serging attachment

REF.NO.	CODE	Q'TY	ヒンメイ	NAME OF PARTS	RM
1	S21336101	1	フチカガリジヨウギクミ	EDGE GUIDE ASSY	
1-1	S23896101	1	ジヨウギトリツケイタ	EDGE GUIDE SET PLATE	
1-2	S23773001	1	ダンネジ4	SHOULDER SCREW, M4	
1-3	146598001	1	バネザガネ	WASHER, SPRING	
1-4	S23897001	1	ジヨウギトリツケイタササエ	EDGE GUIDE SUPPORT	
1-5	021400212	1	2シユナツト4	NUT, 2 M4	
1-6	S21341001	1	ストツパー	STOPPER	
1-7	062300512	1	ナベコ3X5	SCREW, PAN M3X5	
1-8	146762001	1	フチカガリジヨウギ	EDGE GUIDE	
1-9	062350612	1	ナベコM3.5X6	SCREW, PAN M3.5X6	
2	062401012	1	ナベコM4X10	SCREW, PAN M4X10	

878-V5A-236

R. ラフラー装置関係 / Ruffling attachment

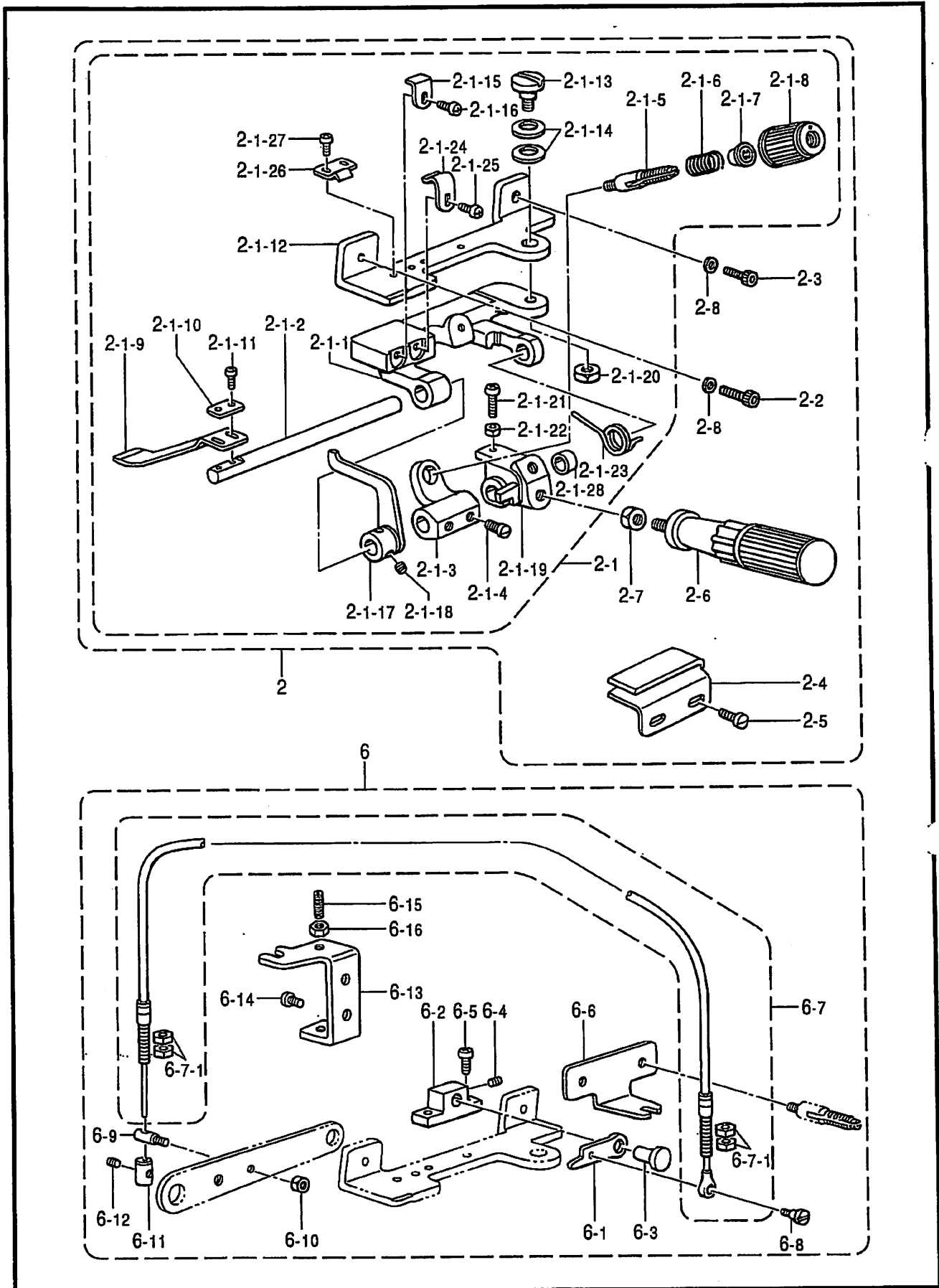

878-V5A-940

R. ラフラー装置関係 / Ruffling attachment

REF.NO.	CODE	Q'TY	ヒンメイ	NAME OF PARTS	RM
2	S30134001	1	ラフラークミ	RUFFLER ASSY	
2-1	S25006001	1	ラフラーソウチクミ	RUFFLER DEVICE SET	
2-1-1	S21294001	1	キジオサエタイ	RUFFLING BLADE BRACKET	
2-1-2	S21295001	1	キジオサエトリツケジク	RUFFLING BLADE BASE SHAFT	
2-1-3	S21305001	1	バネウケ	SPRING BASE	
2-1-4	S23777101	2	アタマツキトメネジ6	SET SCREW, M6	
2-1-5	S20676051	1	イトチヨウシボウ	TENSION STUD	
2-1-6	S23775001	1	コイルバネ	SPRING, COIL	
2-1-7	S20681000	1	チヨウシバネウエザガネ	WASHER	
2-1-8	S20682105	1	イトチヨウシナツト	TENSION NUT	
2-1-9	S25005001	1	キジオサエ	RUFFLING BLADE	
2-1-10	144784001	1	キジオサエザガネ	WASHER	
2-1-11	062300812	2	ナベコ3X8	SCREW, PAN M3X8	
2-1-12	S21297001	1	ラフラーソウチトリツケダイ	RUFFLER BASE	
2-1-13	S21306001	1	ダンネジ6	SHOULDER SCREW, M6	
2-1-14	S21307001	2	バネザガネ	WASHER, SPRING	
2-1-15	S21298001	1	キジオサエアンナイ	RUFFLING BLADE GUIDE	
2-1-16	062400812	1	ナベコ4X8	SCREW, PAN M4X8	
2-1-17	S21299001	1	キジオサエアゲ	CLOTH PRESSER BAR LIFTER	
2-1-18	S23651002	2	アナヒラ6X6ホソメ	SET SCREW, SOCKET (FT) M6X5	
2-1-19	S21300001	1	ハンドルトリツケイタ	HANDLE SETTING PLATE	
2-1-20	021060302	1	ナツト3シユ6	NUT, 3 M6	
2-1-21	062401612	1	ナベコM4X16	SCREW, PAN M4X16	
2-1-22	021400212	1	2シユナツト4	NUT, 2 M4	
2-1-23	S21301001	1	ハンドルモドシバネ	SPRING	
2-1-24	S21302001	1	キジオサエタイトメバネU	SPRING, PLATE (U)	
2-1-25	062400612	1	ナベコM4X6	SCREW, PAN M4X6	
2-1-26	S21303001	1	キジオサエタイトメバネD	SPRING, PLATE (D)	
2-1-27	062350512	2	ナベコ3.5X5	SCREW, PAN M3.5X5	
2-1-28	S21304001	1	カラー	COLLAR	
2-2	018401632	1	アナボルトM4X16	BOLT, SOCKET M4X16	
2-3	018401032	1	アナボルト4X10	BOLT, SOCKET M4X10	
2-4	S21590000	1	キジオアンナイ	RUFFLER GUIDE	
2-5	S23418002	2	シメネジ4X5	SCREW, M4X5	
2-6	S23779001	1	ハンドル	HANDLE	
2-7	021060302	1	ナツト3シユ6	NUT, 3 M6	
2-8	102707002	2	ザガネ	WASHER, PLAIN 4	
6	S30137011	1	ラフラーオサエレンドウクミ	RUFFLING DEVICE SET, JAP.	
6-1	S21310001	1	キジオサエアゲ	CLOTH PRESSER BAR LIFTER LEVER	
6-2	S21311001	1	オサエアゲダイ	PRESSER BAR LIFTER BRACKET	
6-3	S21312001	1	ピン6.35	PIN, 6.35	
6-4	012060632	1	アナヒラ6X6	SET SCREW, SOCKET (FT) M6X6	
6-5	062350812	2	ナベコ3.5X8	SCREW, PAN M3.5X8	
6-6	S21313001	1	ワイヤートリツケイタ	WIRE SET PLATE	
6-7	S21314001	1	フレキシブルワイヤークミ	FLEXIBLE WIRE ASSY	
6-7-1	021500303	4	ナツト3シユ5	NUT, 3 M5	
6-8	S23774001	1	ダンネジ3.5	SHOULDER SCREW, M3.5	
6-9	S21315001	1	スタツドM4	STUD, M4	
6-10	021400212	1	2シユナツト4	NUT, 2 M4	
6-11	S21316001	1	ワイヤーストツパー	WIRE STOPPER	
6-12	012400432	1	アナヒラ4X4	SET SCREW, SOCKET (FT) M4X4	
6-13	S23349001	1	レバーチヨウセツイタ	LEVER ADJUSTING PLATE	
6-14	060400812	2	バインドM4X8	SCREW, BIND M4X8	
6-15	011502012	2	トメネジ5X20ヒラ	SET SCREW, (FT) M5X20	
6-16	021500312	2	3シユナツト5	NUT, 3 M5	

R. ラフラー装置関係 / Ruffling attachment

< 半沈用 / FOR SEMI-SUBMERGED >

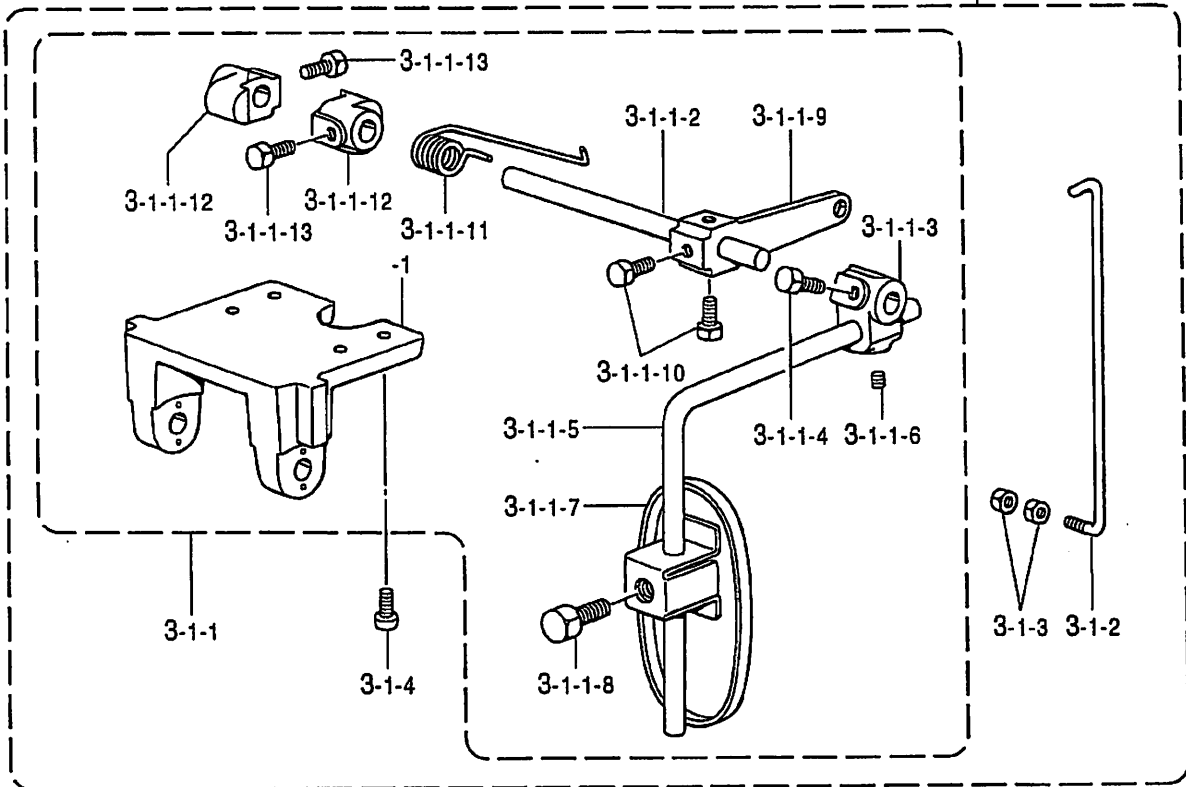

< 全沈用 / FOR FULL-SUBMERGED >

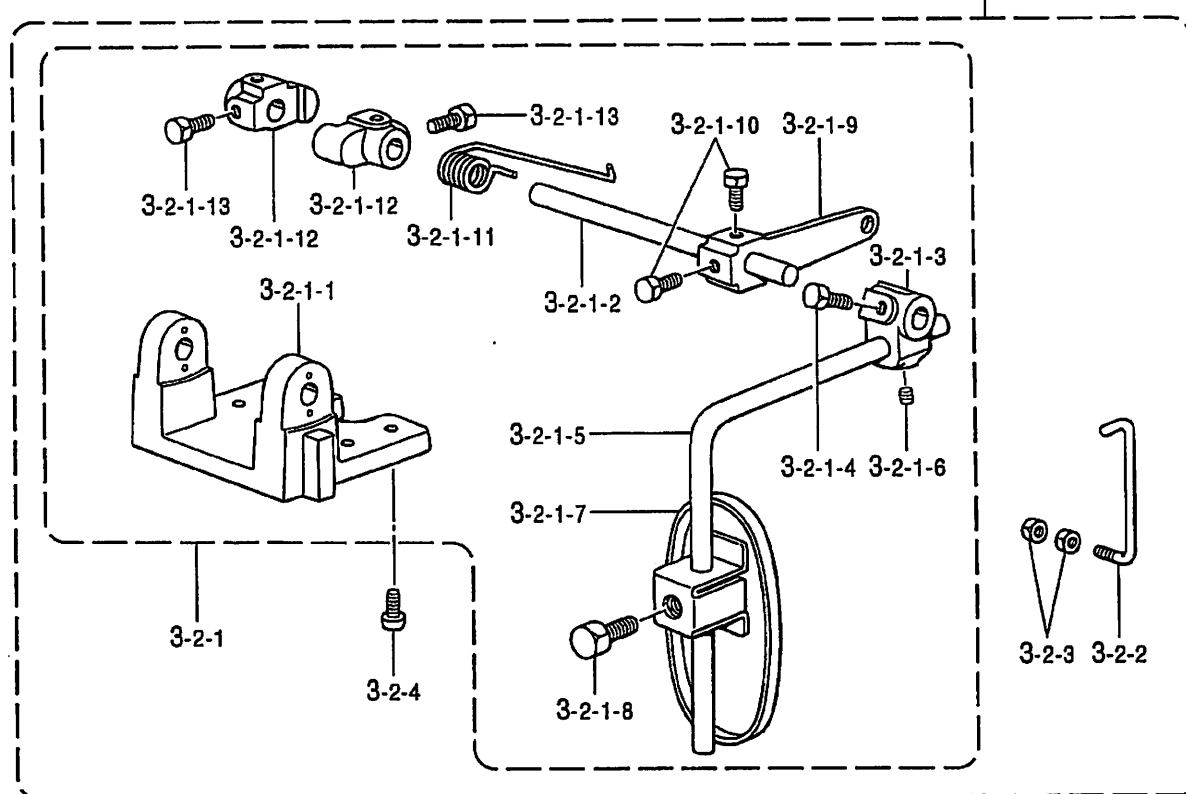

R. ラフラー装置関係 / Ruffling attachment

REF.NO.	CODE	Q'TY	ヒンメイ	NAME OF PARTS	RM
			<半沈用>	< FOR SEMI-SUBMERGED >	
3-1	S30135101	1	サドウチヨウセツセット	DIFFERENTIAL ADJUSTING SET	
3-1-1	S21373101	1	サドウチヨウセツクミ	DIFFERENTIAL FEED ADJUSTER	
3-1-1-1	155197101	1	ヒザアテヨコジクウケ	KNEE LIFTER SHAFT BRACKET	
3-1-1-2	S21375001	1	ヨコジク	KNEE LIFTER SHAET	
3-1-1-3	155199101	1	ヒザアテツギテ	KNEE LIFTER BRACKET	
3-1-1-4	017781012	2	ボルト6.35X10	BOLT, SM6.35X10	
3-1-1-5	148797001	1	ヒザアゲタテジクS	KNEE LIFTER BAR, S	
3-1-1-6	014780622	1	アナトメネジ6.35クボミ	SET SCREW, SOCKET (CP) SM6.35	
3-1-1-7	148798109	1	ヒザアテL	KNEE LIFTER PLATE, L	
3-1-1-8	017081606	1	ボルト8X16	BOLT, M8X16	
3-1-1-9	S21376001	1	ヒザアテレバー	KNEE LIFTER LEVER	
3-1-1-10	017781012	2	ボルト6.35X10	BOLT, SM6.35X10	
3-1-1-11	S21377001	1	ヒザアテレバーバネ	SPRING	
3-1-1-12	S21378001	2	ヨコジクトメグ	COLLAR	
3-1-1-13	017781012	4	ボルト6.35X10	BOLT, SM6.35X10	
3-1-2	S21379001	1	ヒザアテリンク	CONNECTING BAR	
3-1-3	021400202	2	2シユナツト4	NUT, 2 M4	
3-1-4	062401012	4	ナベコM4X10	SCREW, PAN M4X10	
			<全沈用>	< FOR FULL-SUBMERGED >	
3-2	S30135102	1	サドウチヨウセツセット	DIF. ADJUSTING SET, FULL	
3-2-1	S21380101	1	サドウチヨウセツソウチクミ	DIFFERENTIAL FEED ADJUSTER	
3-2-1-1	155197101	1	ヒザアテヨコジクウケ	KNEE LIFTER SHAFT BRACKET	
3-2-1-2	S21375001	1	ヨコジク	KNEE LIFTER SHAET	
3-2-1-3	155199101	1	ヒザアテツギテ	KNEE LIFTER BRACKET	
3-2-1-4	017781012	2	ボルト6.35X10	BOLT, SM6.35X10	
3-2-1-5	148797001	1	ヒザアゲタテジクS	KNEE LIFTER BAR, S	
3-2-1-6	014780622	1	アナトメネジ6.35クボミ	SET SCREW, SOCKET (CP) SM6.35	
3-2-1-7	148798109	1	ヒザアテL	KNEE LIFTER PLATE, L	
3-2-1-8	017081606	1	ボルト8X16	BOLT, M8X16	
3-2-1-9	155201101	1	ヒザアテレバー	KNEE LIFTER LEVER	
3-2-1-10	017781012	2	ボルト6.35X10	BOLT, SM6.35X10	
3-2-1-11	S21377001	1	ヒザアテレバーバネ	SPRING	
3-2-1-12	S21378001	2	ヨコジクトメグ	COLLAR	
3-2-1-13	017781012	4	ボルト6.35X10	BOLT, SM6.35X10	
3-2-2	S21381001	1	ヒザアテリンク	CONNECTING BAR	
3-2-3	021400202	1	2シユナツト4	NUT, 2 M4	
3-2-4	062401012	4	ナベコM4X10	SCREW, PAN M4X10	

R. ラフラー装置関係 / Ruffling attachment

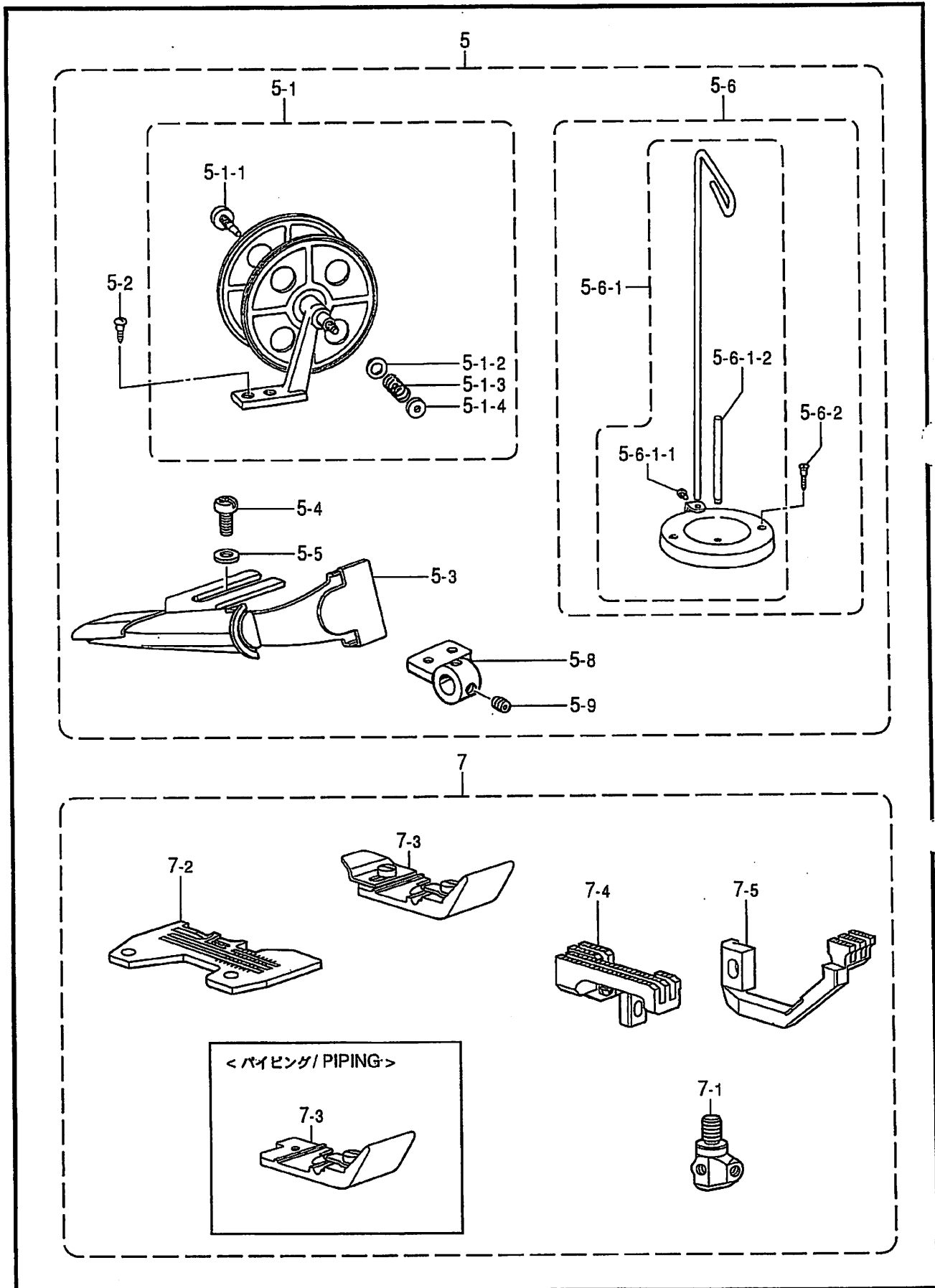

87B-V5A-940

R. ラフラー装置関係 / Ruffling attachment

REF.NO.	CODE	Q'TY	ヒンメイ	NAME OF PARTS	RM
5	S30303001	1	パイピングパーツミ	PIPING PARTS ASSY	
5-1	143767002	1	テープワインダークミ	TAPE WINDER ASSY	
5-1-1	143980001	1	ツマミネジ	SCREW	
5-1-2	108494001	1	ザガネ	WASHER	
5-1-3	108495001	1	テープワインダオシバネ	SPRING	
5-1-4	100136001	1	イトチヨウシナツト	TENSION NUT	
5-2	101118001	2	マルモクネジ4.5X20	WOOD SCREW, ROUND M4.5X20	
5-3	S21318000	1	ラツパークミ	LAPPER ASSY	
5-4	062400812	2	ナベコ4X8	SCREW, PAN M4X8	
5-5	025040232	2	ヒラザガネチユウ4	WASHER, PLAIN M 4	
5-6-1	S20131009	1	イトタテダイクミ	COTTON STAND ASSY	
5-6-1-1	S20134001	1	シメネジW476-24X10	SCREW, W4.76-24X10	
5-6-1-2	S20135001	1	イトタテボウ	SPOOL PIN	
5-6-2	034422006	2	+2サラモク41X20	WOOD SCREW, FLAT 2 M4.1X20	
5-8	S25019001	1	ラツパードダイ	LAPPER BASE	
5-9	S23651002	2	アナヒラ6X6ホソメ	SET SCREW, SOCKET (FT) M6X5	
7	S30291101	1	ラフラーゲージクミ	RUFFLER GAUGE ASSY	
7-3	S19291001	1	オサエクミ <パイピング用>	PRESSER FOOT ASSY <FOR PIPING>	
7	S30292101	1	P.ラフラーゲージクミ	PIPING RUFFLER GAUGE ASSY	
7-3	S25538001	1	オサエクミ	PRESSER FOOT ASSY	
7-1	S20398001	1	ハリドメ2.2クミ	NEEDLE CLAMP ASSY, 2.2	
7-2	S19162001	1	ハリイタ	NEEDLE PLATE	
7-4	S19500001	1	シユオクリバクミ	MAIN FEED DOG ASSY	
7-5	S19243001	1	サドウオクリバ	DIFFERENTIAL FEED DOG	

	REF.NO.	M420-25,W420-25		M620-25,W620-25	
		半沈 Semi- Submerged	全沈 Full- Submerged	半沈 Semi- Submerged	全沈 Full- Submerged
ラフラーシヨウセット/RUFFLER SET		S30293201	S31107201	-	-
P. ラフラーシヨウセット/PIPING RUFFLER SET		-	-	S30295201	S31108201
ラフラーゲージクミ/RUFFLER GAUGE ASSY	7	S30291101	←	-	-
P. ラフラーゲージクミ/PIPING RUFFLER GAUGE ASSY	7	-	-	S30292101	←
ラフラークミ/RUFFLER ASSY	2	S30134001	←	←	←
サドウチヨウセツセット/DIFFERENTIAL ADJUSTING SET	3	S30135101	S30135102	S30135101	S30135102
パイピングパーツクミ/PIPING PARTS ASSY	5	-	-	S30303001	←
ラフラーオサエレンドウクミ/RUFFLING DEVICE SET	6	S30137011	←	←	←

S. バックタック関係 / Back-tacking

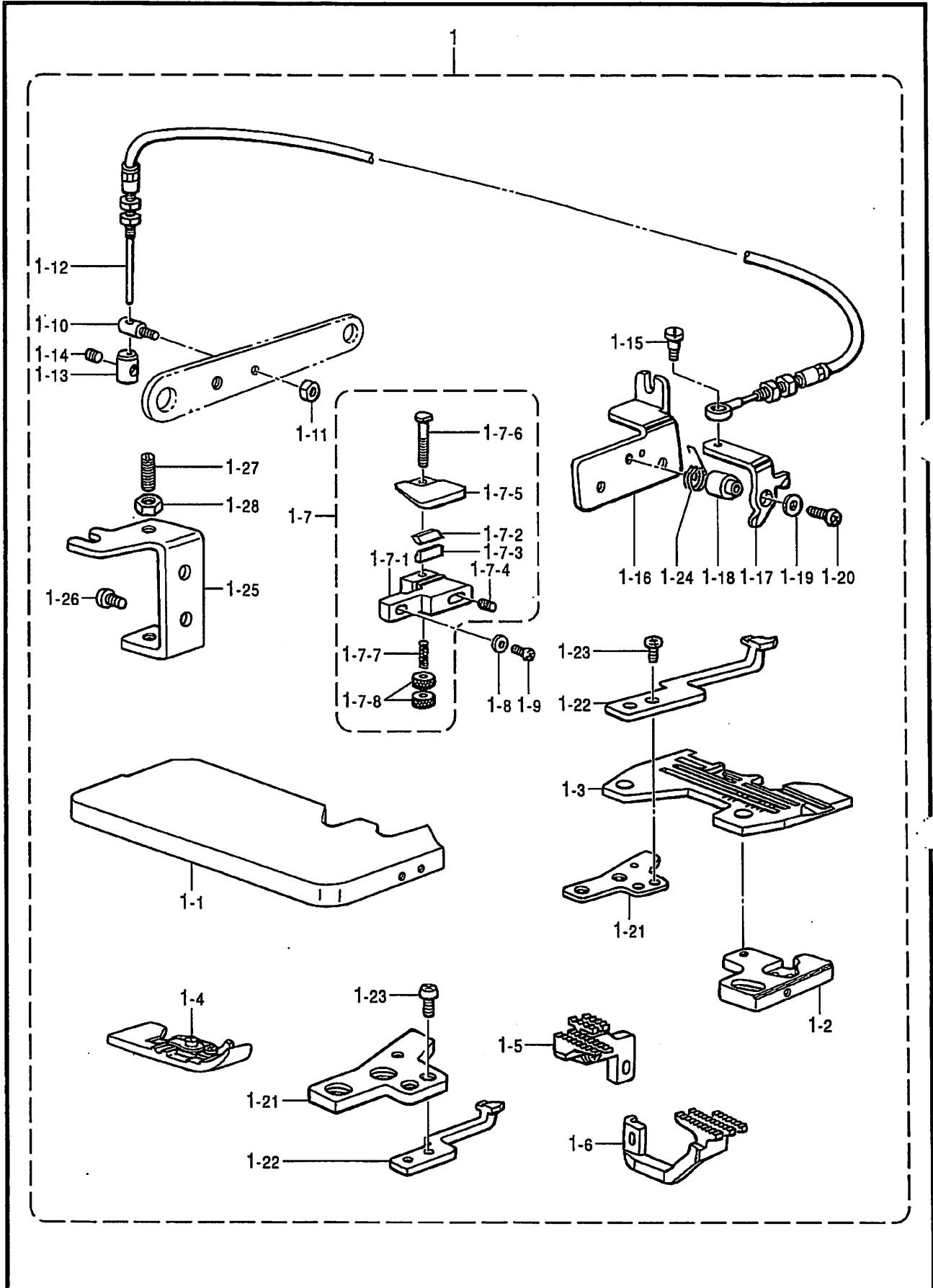

S.バックタック関係 / Back-tacking

REF.NO.	CODE	Q'TY	ヒンメイ	NAME OF PARTS	RM
1	S29898101	1	<W820-25> バックタックソウチセット	BACK-TACK DEVICE SET	
1	S29898102	1	<W820-26> バックタックソウチセット	BACK-TACK DEVICE SET	
1-1	S21334001	1	クロスプレート	CLOTH PLATE	
1-2	S39651051	1	ハリイタササエイタF	NEEDLE PLATE SUPPORT, F	
1-3	※	1	ハリイタ	NEEDLE PLATE	
1-4	S19302001	1	オサエクミ	PRESSER FOOT ASSY	
1-5	S25007001	1	シユオクリバクミ	MAIN FEED DOG ASSY	
1-6	S25010001	1	サドウオクリバ	DIFFERENTIAL FEED DOG	
1-7	S21335001	1	カエシヌイオサエクミ	BACK-TACK PRESSER ASSY	
1-7-1	S21320001	1	カエシヌイドダイ	BACK-TACK BLADE HOLDER	
1-7-2	S09234001	1	カエシヌイメス	BACK-TACK KNIFE	
1-7-3	S09235001	1	カエシヌイメスオサエ	BACK-TACK KNIFE PRESSER	
1-7-4	012400832	2	アナヒラ4X8	SET SCREW, SOCKET (FT) M4X8	
1-7-5	S21321001	1	カエシヌイオサエイタ	BACK-TACK PRESSER PLATE	
1-7-6	S21322001	1	オサエイタオシボウ	PRESSER PLATE SHAFT	
1-7-7	116794001	1	オシバネ	SPRING, COMPRESSION	
1-7-8	S21324001	2	オサエイタチヨウセツナツト	PRESSER PLATE ADJUSTING NUT	
1-8	025040132	1	ヒラザガネシヨウ4	WASHER, PLAIN S 4	
1-9	060401012	1	バインドM4X10	SCREW, BIND M4X10	
1-10	S21315001	1	スタツドM4	STUD, M4	
1-11	021400212	1	2シユナツト4	NUT, 2 M4	
1-12	S21314001	1	フレキシブルワイヤークミ	FLEXIBLE WIRE ASSY	
1-13	S21316001	1	ワイヤーストツパー	WIRE STOPPER	
1-14	012400432	1	アナヒラ4X4	SET SCREW, SOCKET (FT) M4X4	
1-15	S23774001	1	ダンネジ3.5	SHOULDER SCREW, M3.5	
1-16	S21327001	1	イトユルメドダイ	TENSION RELEASE BASE	
1-17	S21328001	1	イトユルメイタ	TENSION RELEASE PLATE	
1-18	S23784001	1	カラー	COLLAR	
1-19	025040232	1	ヒラザガネチユウ4	WASHER, PLAIN M 4	
1-20	062401212	1	ナベコ4X12	SCREW, PAN M4X12	
1-21	S23786001	1	ハリイタササエイタB	NEEDLE PLATE SUPPORT PLATE, B	
1-22	S21326001	1	イトサバキ	THREAD RETAINER	
1-23	062300512	2	ナベコ3X5	SCREW, PAN M3X5	
1-24	S30443001	1	イトユルメモドシバネ	SPRING	
1-25	S23349001	1	レバーチヨウセツイタ	LEVER ADJUSTING PLATE	
1-26	060400812	2	バインドM4X8	SCREW, BIND M4X8	
1-27	011502012	2	トメネジ5X20ヒラ	SET SCREW, (FT) M5X20	
1-28	021500312	2	3シユナツト5	NUT, 3 M5	

Z. 付属品関係 / Accessories

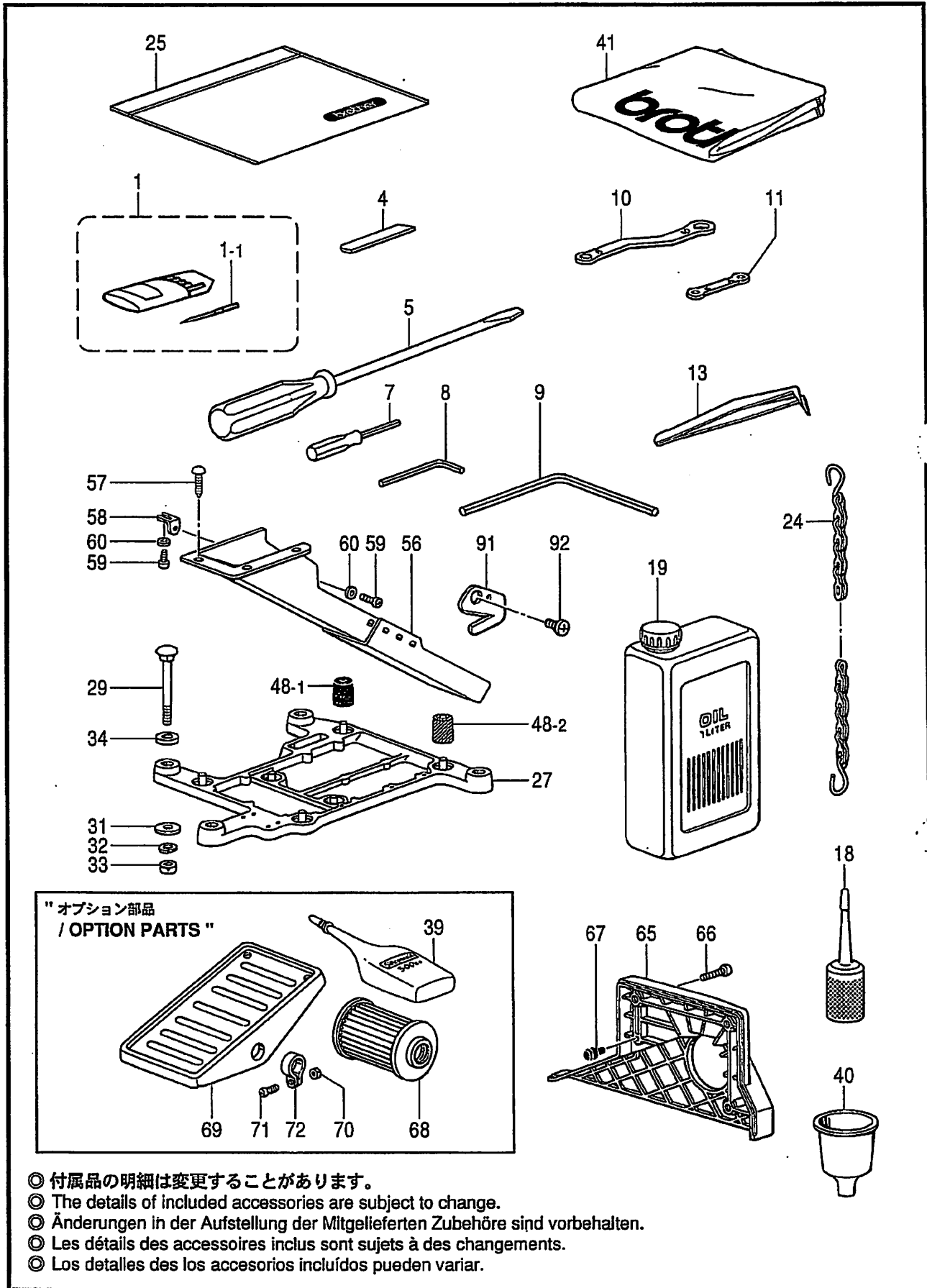

Z. 付属品関係 / Accessories

REF.NO.	CODE	Q'TY	ヒンメイ	NAME OF PARTS	RM
1		2	ミシンハリクミ	NEEDLE ASSY, DCX27	
1-1	※	8	ミシンハリ	NEEDLE, DCX27	
4	※	1	シタメス	LOWER KNIFE	
5	101572101	1	ネジマワシ5.5X190	SCREW DRIVER, 5.5X190	
7	S01943001	1	6カクボウネジマワシ1.6	SCREW DRIVER, 1.6	
8	142002001	1	6カクボウスパナ2	HEXAGONAL WRENCH, 2	
9	149570001	1	6カクボウスパナ5	HEXAGONAL WRENCH, 5	
10	S23356001	1	メガネレンチ8X10	DOUBLE WRENCH, 8X10	
11	S46907001	1	メガネレンチ5X6	DOUBLE WRENCH, 5X6	
13	117466000	1	ピンセット	PINCETTE	
18	S06701000	1	ポリオイラークミ	POLY OILER ASSY	
19	145277205	1	オイルタンク	OIL TANK	
24	142262001	1	クサリフクミ	CHAIN, F ASSY	
25	122991001	1	フソクヒンポリフクロ	ACCESSORY BAG	
27	S20718000	1	トウブウケ	HEAD PLATE	
29	S35997001	4	カクネボルト8X85	BOLT, M8X85	
31	213650001	4	ワ2.3X8.5X385T	WASHER, 2.3X8.5X385T	
32	028080242	4	バネザガネ2-8	WASHER, SPRING 2-8	
33	021080106	4	ナツト1シユ8	NUT, 1 M8	
34	S20719000	4	クツシヨン	CUSHION	
39	S06704001	1	シリコンオイル	-----	
40	S20769000	1	ジヨーゴ	FUNNEL	
41	144225002	1	トウブカバー	HEAD COVER	
48-1	147919051	1	ボウシンゴム	RUBBER CUSHION	
48-2	147919052	3	ボウシンゴム	RUBBER CUSHION	
56	183797009	1	ダスターシユートクミ	DUSTER CHUTE ASSY	
57	031411304	3	マルモクネジ4.1X13	WOOD SCREW, ROUND M4.1X13	
58	S23353001	1	ダスターシユートササエS	DUSTER SHOOT SUPPORT, S	
59	062400612	2	ナベコM4X6	SCREW, PAN M4X6	
60	025040332	2	ヒラザガネダイ4	WASHER, PLAIN L 4	
65	S38645001	1	ベルトカバークミ	BELT COVER ASSY	
66	062061412	3	ナベコ6X14	SCREW, PAN M6X14	
67	S20412000	1	ゴムセン3.7	RUBBER CAP, 3.7	
68	S08956100	1	オイルフィルター	-----	
69	147893009	1	オサエアゲフミイタ	-----	
70	021400106	2	ナツト1シユ4	-----	
71	062401406	2	ナベコ4X14	-----	
72	116016001	2	ペタルトメ	-----	
91	S20118151	1	カラヌイメス	TRIMMING KNIFE	
92	060300512	1	バインドM3X5	SCREW, BIND M3X5	
39	S06704001	1	-----	<OPTION PARTS> SILICONE OIL	
68	S08956100	1	-----	OIL FILTER	
69	147893009	1	-----	TREADLE PEDAL	
70	021400106	2	-----	NUT, 1 M4	
71	062401406	2	-----	SCREW, PAN M4X14	
72	116016001	2	-----	PEDAL STOPPER	

Z. 付属品関係 / Accessories

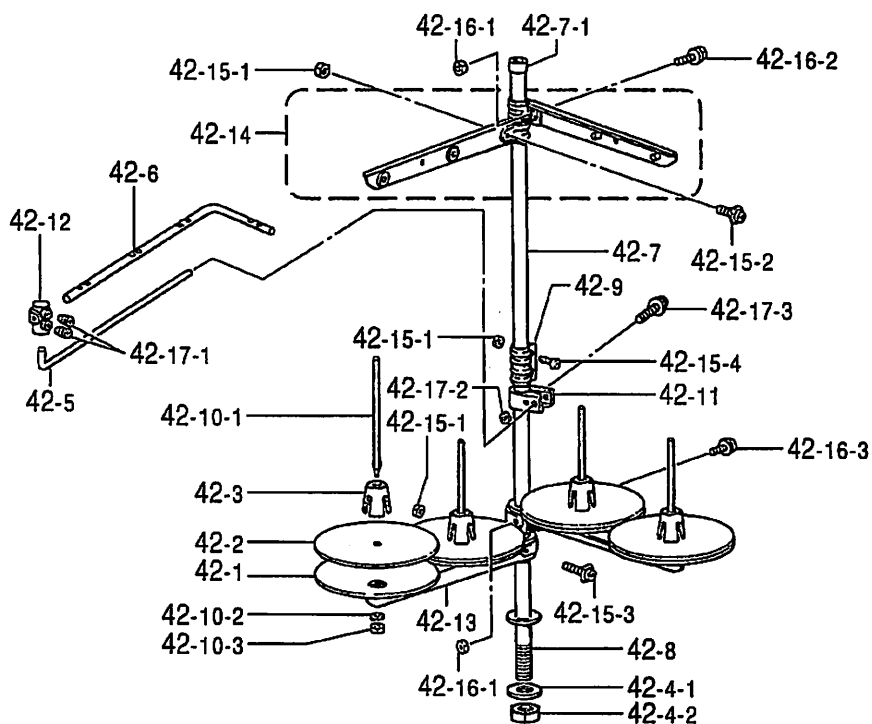

" オプション部品 / OPTION PARTS "

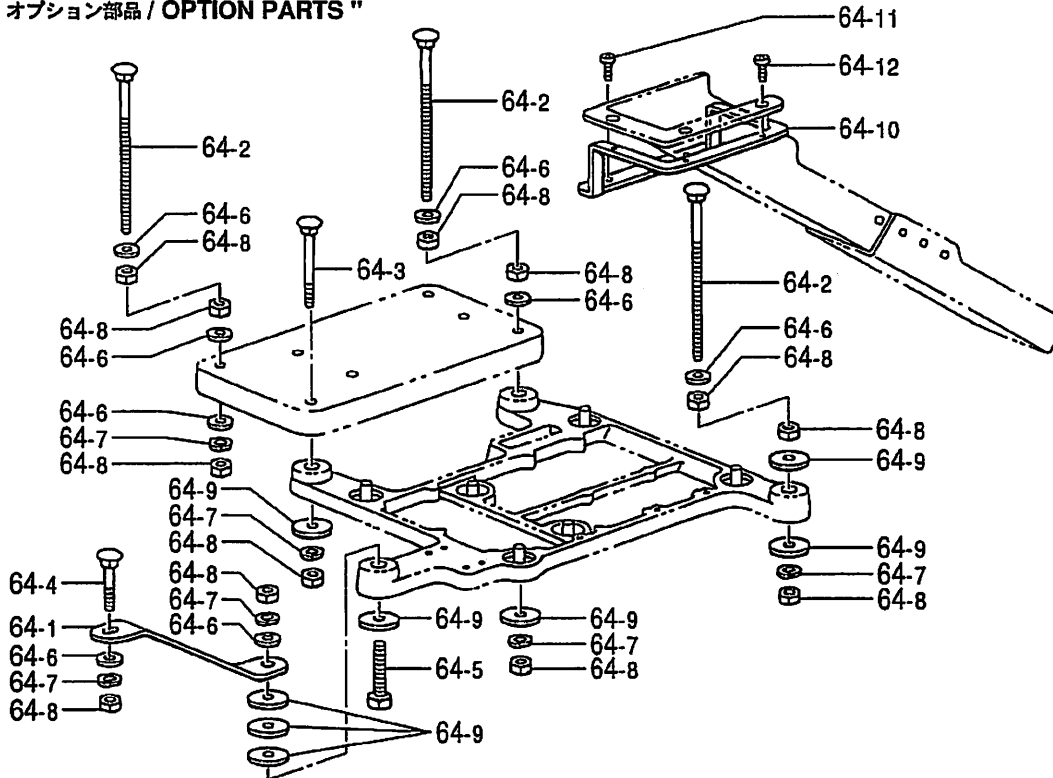

















- ◎ 付属品の明細は変更することがあります。
- ◎ The details of included accessories are subject to change.
- ◎ Änderungen in der Aufstellung der Mitgelieferten Zubehöre sind vorbehalten.
- ◎ Les détails des accessoires inclus sont sujets à des changements.
- ◎ Los detalles de los accesorios incluidos pueden variar.

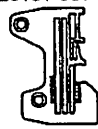
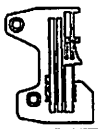
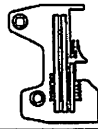
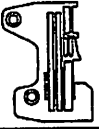
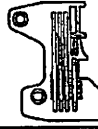
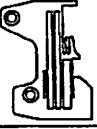
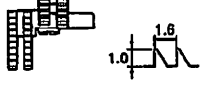
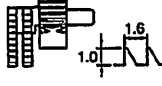
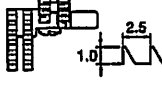
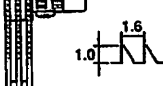
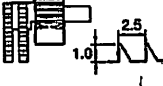
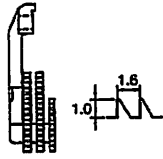
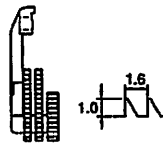
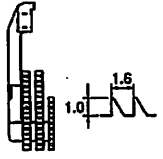
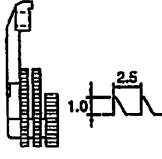
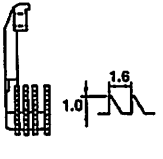
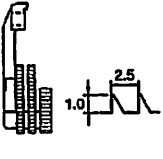



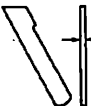









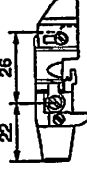

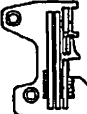
Z. 付属品関係 / Accessories

REF.NO.	CODE	Q'TY	ヒンメイ	NAME OF PARTS	RM
42	S29854109	1	イトタテダイクミ4DTHF	COTTON STAND ASSY, 4DTHF	
42-1	150180001	4	ウケザラ	SPOOL STAND BASE	
42-2	150182000	4	スプールマット	SPOOL MAT	
42-3	126863001	4	スプールクッション	SPOOL CUSHION	
42-4	S02775001	1	パイプネジセットA	PIPE SCREW SET, A	
42-4-1	150206002	1	ヒラザガネ16	WASHER, PLAIN 16	
42-4-2	S38648001	1	6カクナツトU5/8	NUT, U5/8-28	
42-5	S04109001	1	イトアンナイササエボウ	THREAD GUIDE SUPPORT BAR	
42-6	142998001	1	イトアンナイ4	THREAD GUIDE, 4	
42-7	S40640001	1	コラムパイプキャップツキ	COLUMN PIPE WITH CAP	
42-7-1	150174000	1	コラムキャップ	COLUMN CAP	
42-8	156112003	1	コラムパイプD	COLUMN PIPE, D	
42-9	150173003	1	コラムジョイント	COLUMN JOINT	
42-10	S21798001	4	スプールネジセット	SPOOL SCREW SET	
42-10-1	150179002	4	スプールジクB	SPOOL SHAFT, B	
42-10-2	028050246	4	バネザガネ2-5	WASHER, SPRING 2-5	
42-10-3	021500106	4	1シユナツト5	NUT, 1 M5	
42-11	150185009	1	イトアンナイホルダー	THREAD GUIDE HOLDER	
42-12	138843001	1	ササエボウツギテ	JOINT	
42-13	S02778002	2	スプールホルダー2	SPOOL HOLDER, 2	
42-14	S02786002	2	スレッドハンガークミ2	THREAD HANGER ASSY, 2	
42-15	S40641001	1	スプールジクネジセットA	SPOOL SCREW SET, A	
42-15-1	021500106	4	1シユナツト5	NUT, 1 M5	
42-15-2	S37038001	1	ナベコヒラザ5X14	SCREW, PAN (S/P WASHER) M5X14	
42-15-3	S37037001	1	ナベコヒラザ5X32	SCREW, PAN (S/P WASHER) M5X32	
42-15-4	062501406	2	ナベコ5X14	SCREW, PAN M5X14	
42-16	S40642001	1	スプールジクネジセットB	SPOOL SCREW SET, B	
42-16-1	021500106	2	1シユナツト5	NUT, 1 M5	
42-16-2	S37038001	1	ナベコヒラザ5X14	SCREW, PAN (S/P WASHER) M5X14	
42-16-3	S37037001	1	ナベコヒラザ5X32	SCREW, PAN (S/P WASHER) M5X32	
42-17	S40643001	1	ホルダーツギテネジセット	HOLDER JOINT SCREW SET	
42-17-1	014060632	2	アナトメ6X6クボミ	SET SCREW, SOCKET (CP) M6X6	
42-17-2	021500106	1	1シユナツト5	NUT, 1 M5	
64	183798001	1	フルサブマージセット	FULL SUBMERGED SET	
64-1	S20721001	1	トウブウケササエ	HEAD PLATE SUPPORT	
64-2	153318201	4	カクネマルアタマボルト	BOLT	
64-3	S35997001	1	カクネボルト8X85	BOLT, M8X85	
64-4	S36007001	1	カクネボルト8X55	BOLT, M8X55	
64-5	017085502	1	ボルトM8X55	BOLT, M8X55	
64-6	025080236	11	ヒラザガネチユウ8	WASHER, PLAIN M 8	
64-7	028080242	7	バネザガネ2-8	WASHER, SPRING 2-8	
64-8	021080106	15	ナツト1シユ8	NUT, 1 M8	
64-9	213650001	8	ワ2.3X8.5X38ST	WASHER, 2.3X8.5X38ST	
64-10	S20722001	1	ダスターシュートササエL	DUSTER SHOOT SUPPORT, L	
64-11	060400812	2	バインドM4X8	SCREW, BIND M4X8	
64-12	060400812	3	バインドM4X8	SCREW, BIND M4X8	

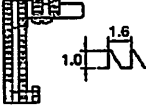
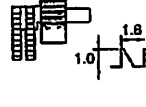
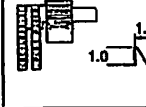
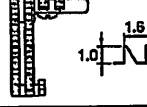
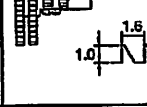
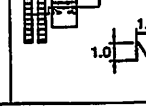
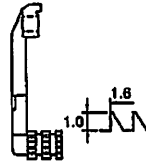
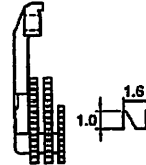
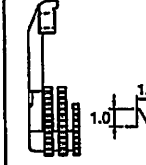
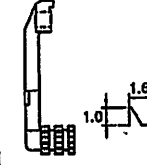
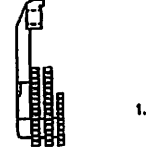
Ga1 . ゲージ部品一覧表 / Gauge parts List

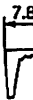
用途 Application	一般地縫用 Thin Medium (1本外シ) (Mock-Safety)		一般地縫用 Thin Medium (小回り用) (For small type) (1本外シ) (Mock-Safety)	デニム用 Heavy (1本外シ) (Mock-Safety)	バルキーニット用 Bulky knit (1本外シ) (Mock-Safety)	
	M020-24-H3F -25-H3F -26-H3F -27-H3F	M020-35-H3F -36-H3F -37-H3F	M021-25-H8F -26-H8F -27-H8F	M040-36-E3W -37-E3W	M060-25-H4V -26-H4V -27-H4V	M060-25-H8V -26-H8V -27-H8V
針巾 (mm) Needle Gauge	2.2	3	2.2	3	2.2	
1 針 Needle	151474-011			151474-018	151474-014	
2 押工組 Presser Foot Assy (ツメ Stitch Tongue)	S25543-001 (4) (S25544-001) S19280-001 (5) (S19976-001) S19282-001 (6, 7) (S19283-001) 	S19284-001 (5) (S19976-001) S19285-001 (6) (S19286-001) S19289-001 (7) (S19975-001) 	S29952-001 (4) (S25544-001) S29950-001 (5) (S19976-001) S29951-001 (6, 7) (S19283-001) 	S29871-001 (6) (S19286-001) S29869-001 (7) (S19975-001) 	S19287-201 (5) (S19976-001) S19288-201 (6, 7) (S19283-001) 	
3 針止メ組 Needle Clamp Assy	S20398-001 	S20402-001 	S20398-001 	S20402-001 	S20398-001 	
4 針板 Needle Plate	S25190-001 (4) S19162-001 (5) S19163-001 (6) S25191-001 (7) 	S19164-001 (5) S19165-001 (6) S19168-001 (7) 	S19169-001 (5) S19170-001 (6) S25193-001 (7) 	S24663-001 (6) S24664-001 (7) 	S25528-001 (5) S19188-001 (6) S25529-001 (7) 	S19166-001 (5) S19167-001 (6) S25192-001 (7) 
5 主送り歯組 Main Feed Dog Assy (主送り歯 Main Feed Dog) (補助送り歯 Chain Feed Dog)	S19199-001 (S19200-001) (S19201-001) A 		S19212-001 (S19213-001) (S19204-001) B 	S21392-001 (S21393-001) (S21394-001) J 	S24680-001 (S24681-001) (S19201-001) A 	S19202-001 (S19955-001) (S19204-001) B 
6 差動送り歯 Differential Feed Dog	S19236-001 	S19242-001 	S19240-001 	S21395-001 	S30894-101 	S19237-101 
7 上メス Upper Knife 角メス Angle Knife	上メス Upper knife 144074-350 			角メス Angle knife S20898-101 	角メス Angle knife S20897-101 	
8 下メス Lower Knife 	S20582-001 (T=1.5)	(5) S20899-001 (T=1.0) (6, 7) S20582-001 (T=1.5)	S20582-001 (T=1.5)	S20583-001 	(5) S20899-001 (T=1.0) (6, 7) S20582-001 (T=1.5)	
9 上ルーバ Over Looper 	S20436-001 (4, 5, 7) F S20424-001 (6) B	S20434-001 E	S20436-001 (5, 7) F S20424-001 (6) B	S20442-001 R	S20434-001 E	













Ga2 . ゲージ部品一覧表 / Gauge parts List

用途 Application	ラフラー用 (1本外シ) Ruffling (Mock-Safety)	テープ用 Taping (1本外シ) (Mock-Safety)	バルキーニット (テープ用) Bulky knit (Taping) (1本外シ) (Mock-Safety)	パイピングラフラー用 Ruffling W / Piping (1本外シ) (Mock-Safety)	一般地縫用 Thin Medium	
					チェーンランドあり With Chain Land	チェーンランドなし Without Chain Land
サブクラス Sub-Class H=High-Lift E=Extra High-Lift	M420-25-H3F	M520-25-H8F -26-H8F	M560-25-H8V -26-H8V -27-H8V	M620-25-H3F -26-H3F	W020-24-H3F -25-H3F -26-H3F -27-H3F	W020-24-H8F -25-H8F -26-H8F -27-H8F
針巾 (mm) Needle Gauge	2.2					
1 針 Needle	151474-011		151474-014	151474-011		
2 押工組 Presser Foot Assy (ツメ Stitch Tongue)	S19291-001 	S19293-001 (5) (S19974-001) S25546-001 (6) (S25547-001) 	S19297-001 (5) (S19976-001) S19301-001 (6, 7) (S19283-001) 	S25538-001 	S25543-001 (4) (S25544-001) S19280-001 (5) (S19976-001) S19282-001 (6, 7) (S19283-001) 	
針止め組 Needle Clamp Assy	S20398-001 					
4 針板 Needle Plate	S19162-001 	S19169-001 (5) S19170-001 (6) S25193-001 (7)		S19162-001 (5) S19163-001 (6) 	S25190-001 (4) S19162-001 (5) S19163-001 (6) S25191-001 (7) 	S25527-001 (4) S19169-001 (5) S19170-001 (6) S25193-001 (7) 
5 主送り歯組 Main Feed Dog Assy (主送り歯 Main Feed Dog) (補助送り歯 Main Feed Dog)	S19500-001 (S19218-001) (S19201-001) A 	S19212-001 (S19213-001) (S19204-001) B 	S19219-001 (S19220-001) (S19204-001) B 	S19500-001 (S19218-001) (S19201-001) A 	S19217-001 (S19213-001) (S19201-001) A 	S19212-001 (S19213-001) (S19204-001) B 
6 差動送り歯 Differential Feed Dog	S19243-001 	S19240-001 	S19244-101 	S19243-001 	S19240-001 	
7 上メス Upper Knife 角メス Angle Knife	上メス Upper knife 144074-350 		角メス Angle knife S20897-101 		上メス Upper knife 144074-350 	
8 下メス Lower Knife 	S20582-001 (T=1.5)					
9 上ルーバ Over Looper 	S20436-001 F		S20434-001 E	S20436-001 F	S20424-001 B	

Ga3 . ゲージ部品一覧表 / Gauge parts List

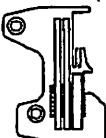
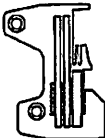
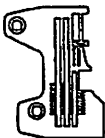
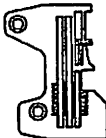
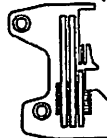
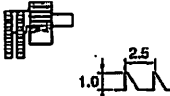
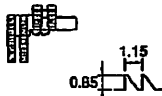
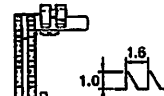
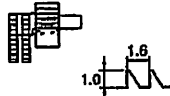
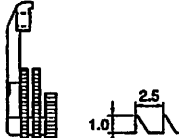
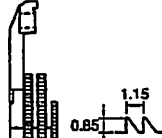
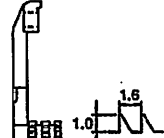
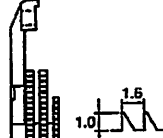
用途 Application	一般地縫用 Thin Medium		デニム用 Heavy		バルキーニット用 Bulky knit
		(小回り用) (For small type)		(トラクター押工) (Tractor Type)	
サブクラス Sub-Class H=High-Lift E=Extra High-Lift	W020-35-H3F -36-H3F -37-H3F	W021-24-H8F -25-H8F -26-H8F -27-H8F	W040-36-E3W -37-E3W	W050-36-E3W -37-E3W	W060-25-H4V -26-H4V -27-H4V
針巾 (mm) Needle Gauge	3	2.2	3		2.2
1 針 Needle	151474-011		151474-018		151474-014
2 押工組 Presser Foot Assy (ツメ) (Stitch Tongue)	S19284-001 (5) (S19976-001) S19285-001 (6) (S19286-001) S19289-001 (7) (S19975-001) 	S29952-001 (4) (S25544-001) S29950-001 (5) (S19976-001) S29951-001 (6, 7) (S19283-001) 	S29871-001 (6) (S19286-001) S29869-001 (7) (S19975-001) 	S30898-001 (S30900-001) 	S19287-201 (5) (S19976-001) S19288-201 (6, 7) (S19283-001)
3 針止め組 Needle Clamp Assy	S20402-001 	S20398-001 	S20402-001 		S20398-001
4 針板 Needle Plate	S19164-001 (5) S19165-001 (6) S19168-001 (7) 	S25527-001 (4) S19169-001 (5) S19170-001 (6) S25193-001 (7) 	S24663-001 (6) S24664-001 (7) 		S25528-001 (5) S19188-001 (6) S25529-001 (7)
5 主送り歯組 Main Feed Dog Assy (主送り歯) (Main Feed Dog) (補助送り歯) (Chain Feed Dog)	S19199-001 (S19200-001) (S19201-001) A 	S19212-001 (S19213-001) (S19204-001) B 	S21392-001 (S21393-001) (S21394-001) J 		S24680-001 (S24681-001) (S19201-001) A
6 差動送り歯 Differential Feed Dog	S19242-001 	S19240-001 	S21395-001 		S30894-101
7 上メス Upper Knife 角メス Angle Knife	上メス Upper knife 144074-350 		角メス Angle knife S20898-101 		角メス Angle knife S20897-101
8 下メス Lower Knife 	(5) S20899-001 (T=1.0) (6, 7) S20582-001 (T=1.5)	S20582-001 (T=1.5)	S20583-001 T=1.5 		(5) S20899-001 (T=1.0) (6, 7) S20582-001 (T=1.5)
9 上ルーバ Over Looper 	S20432-001 J	S20424-001 B	S20438-101 G		S20430-001 D

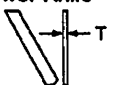

Ga4 . ゲージ部品一覧表 / Gauge parts List

用途 Application	バルキーニット用 Bulky knit		SS用 New Synthetic Fiber	ラフラー用 Ruffling	テープ用 Taping
サブクラス Sub-Class H=High-Lift E=Extra High-Lift	W060-25-H8V -26-H8V -27-H8V	W070-X6-E8V -X7-E8V	W0S0-25-H3F	W420-25-H3F	W520-25-H8F -26-H8F
針巾 (mm) Needle Gauge	2.2	2.5	2.2		
1 針 Needle	151474-014		151474-039	151474-011	
2 押エ組 Presser Foot Assy (ツメ Stitch Tongue)	S19287-201 (5) (S19976-001) S19288-201 (6, 7) (S19283-001) 	S19303-201 (6) (S19286-001) S20881-201 (7) (S19975-001) 	S36867-001 (S19976-001) 	S19291-001 	S19293-001 (5) (S19974-001) S25546-001 (6) (S25547-001) 
針止め組 Needle Clamp Assy	S20398-001 	S20400-001 	S20398-001 		
4 針板 Needle Plate	S19166-001 (5) S19167-001 (6) S25192-001 (7) 	S19173-001 (6) S20880-001 (7) 	S36866-001 	S19162-001 	S19169-001 (5) S19170-001 (6) S25193-001 (7) 
5 主送り歯組 Main Feed Dog Assy (主送り歯 Main Feed Dog) (補助送り歯 Main Feed Dog)	S19202-001 (S19955-001) (S19204-001) B 		S36738-001 (S36739-001) (S19201-001) A 	S19500-001 (S19218-001) (S19201-001) A 	S19212-001 (S19213-001) (S19204-001) B 
6 差動送り歯 Differential Feed Dog	S19237-101 		S36740-001 	S19243-001 	S19240-001 
7 上メス Upper Knife 角メス Angle Knife	角メス Angle knife S20897-101 		上メス Upper knife 144074-350 		
8 下メス Lower Knife 	(5) S20899-001 (T=1.0) (6, 7) S20582-001 (T=1.5)	S20582-001 (T=1.5)			
9 上ルーパ Over Looper 	S20430-001 D	S20440-101 K	S20424-001 B		

Ga5 . ゲージ部品一覧表 / Gauge parts List

用途 Application	バルキーニット (テープ用) Bulky knit (Taping)	パイピング ラフラー用 Ruffling W / Piping	バックタック用 Back-Tacking	バルキーニットバックタック用 Bulky knit Back-Tacking
サブクラス Sub-Class H=High-Lift E=Extra High-Lift	W520-25-H8V -26-H8V -27-H8V	W620-25-H3F -26-H3F	W820-25-H3F -26-H3F	W870-X6-E8V
針巾 (mm) Needle Gauge	2.2			2.5
1 針 Needle	151474-014	151474-011	151474-011	151474-014
2 押工組 Presser Foot Assy (ツメ (Stitch Tongue)	S19297-001 (5) (S19976-001) S19301-001 (6,7) (S19283-001) 	S25538-001 	S19302-001 (5,6) (S19977-001) 	S19303-201 (S19286-001)
3 針止め組 Needle Clamp Assy	S20398-001 			S20400-001
4 針板 Needle Plate	S19169-001 (5) S19170-001 (6) S25193-001 (7) 	S19162-001 (5) S19163-001 (6) 	S19981-001 (5) S19982-001 (6) 	S33529-001
5 主送り歯組 Main Feed Dog Assy (主送り歯 Main Feed Dog) (補助送り歯 Chain Feed Dog)	S19219-001 (S19220-001) (S19204-001) B 	S19500-001 (S19218-001) (S19201-001) A 	S25007-001 (S25008-001) (S25009-001) K 	S33530-001 (S33531-001) (S19204-001) B
6 差動送り歯 Differential Feed Dog	S19244-101 	S19243-001 	S25010-001 	S33536-001
7 上メス Upper Knife 角メス Angle Knife	角メス Angle knife S20897-101 	上メス Upper knife 144074-350 		角メス Angle knife S20897-101
8 下メス Lower Knife 	S20582-001 (T=1.5)			
9 上ルーバ Over Looper 	S20430-001 D	S20424-001 B	S20424-001 B	S20440-101 K

Wa. 警告ラベル / Warning labels

警告ラベル / Warning labels	品名 / Name of parts	Size(mm)	Code
	操作注意ラベル・和	40×64	S38350-001
	Label, operation Eng.	40×64	S38349-001
	アースマーク Mark, grounding	ø12	S37060-001

878-V5A-052

索引 / INDEX

CODE	REF.NO.	Page
S00075000	A - 66	4
S01295001	D - 50-1-5	12
	D - 50-19-5	14
	D - 50-25-2	14
	D - 50-26-5	14
S01943001	Z - 7	40
S02573000	E - 38	16
S02606000	A - 3	2
S02775001	Z - 42-4	42
S02778002	Z - 42-13	42
S02786002	Z - 42-14	42
S02874001	P - 1-3	30
S04109001	Z - 42-5	42
S06701000	Z - 18	40
S06704001	Z - 39	40
	Z - 39	40
S07477009	A - 84	4
S08956100	L - 8	26
	Z - 68	40
	Z - 68	40
S08957001	L - 7	26
S09234001	S - 1-7-2	38
S09235001	S - 1-7-3	38
S12987002	L - 10	26
S19162001	R - 7-2	36
	Ga1 - 4	43
	Ga3 - 4	45
	Ga4 - 4	46
S19163001	Ga1 - 4	43
	Ga4 - 4	46
S19164001	Ga2 - 4	44
S19165001	Ga2 - 4	44
S19166001	Ga2 - 4	44
S19167001	Ga2 - 4	44
S19168001	Ga2 - 4	44
S19169001	Ga1 - 4	43
	Ga4 - 4	46
S19170001	Ga1 - 4	43
	Ga4 - 4	46
S19173001	Ga5 - 4	47
S19188001	Ga2 - 4	44
S19199001	Ga1 - 5	43
	Ga2 - 5	44
S19200001	Ga1 - 5	43
	Ga2 - 5	44
S19201001	Ga1 - 5	43
	Ga2 - 5	44
	Ga3 - 5	45
	Ga4 - 5	46
S19202001	Ga2 - 5	44
	Ga5 - 5	47
S19204001	Ga1 - 5	43
	Ga2 - 5	44
	Ga4 - 5	46
	Ga5 - 5	47
S19212001	Ga1 - 5	43
	Ga4 - 5	46
S19213001	Ga1 - 5	43
	Ga4 - 5	46
S19217001	Ga1 - 5	43
S19218001	Ga3 - 5	45
	Ga4 - 5	46
S19219001	Ga4 - 5	46

CODE	REF.NO.	Page
S19220001	Ga4 - 5	46
S19236001	Ga1 - 6	43
S19237101	Ga2 - 6	44
	Ga5 - 6	47
S19240001	Ga1 - 6	43
	Ga4 - 6	46
S19242001	Ga2 - 6	44
S19243001	R - 7-5	36
	Ga3 - 6	45
	Ga4 - 6	46
S19244101	Ga4 - 6	46
S19258001	D - 50-1-4	12
	D - 50-26-4	14
S19259001	D - 50-1-6	12
	D - 50-2-4	12
	D - 50-9-3	12
	D - 50-10-6	12
	D - 50-19-6	14
S19279001	D - 50-11-4	12
	D - 50-18-4	12
S19280001	Ga1 - 2	43
S19282001	Ga1 - 2	43
S19283001	Ga1 - 2	43
	Ga2 - 2	44
	Ga4 - 2	46
S19284001	Ga2 - 2	44
S19285001	Ga2 - 2	44
S19286001	Ga2 - 2	44
	Ga3 - 2	45
	Ga5 - 2	47
S19287201	Ga2 - 2	44
S19288201	Ga2 - 2	44
S19289001	Ga2 - 2	44
S19291001	R - 7-3	36
	Ga3 - 2	45
S19293001	Ga4 - 2	46
S19296001	D - 50-10-4	12
S19297001	Ga4 - 2	46
S19299001	D - 50-11-7	12
S19300001	D - 50-11-5	12
S19301001	Ga4 - 2	46
S19302001	S - 1-4	38
	Ga5 - 2	47
S19303201	Ga5 - 2	47
S19311101	D - 50-25-7	14
S19496001	D - 50-1-2	12
	D - 50-2-2	12
	D - 50-9-1	12
	D - 50-10-2	12
	D - 50-11-2	12
	D - 50-14-1	14
	D - 50-18-2	12
	D - 50-19-2	14
	D - 50-26-6	14
S19500001	R - 7-4	36
	Ga3 - 5	45
	Ga4 - 5	46
S19955001	Ga2 - 5	44
	Ga5 - 5	47
S19974001	Ga4 - 2	46
S19975001	Ga2 - 2	44
	Ga3 - 2	45
	Ga5 - 2	47

CODE	REF.NO.	Page
S19976001	Ga1 - 2	43
	Ga2 - 2	44
	Ga4 - 2	46
S19977001	Ga5 - 2	47
S19981001	Ga5 - 4	47
S19982001	Ga5 - 4	47
S20118151	Z - 91	40
S20131009	R - 5-6-1	36
S20134001	R - 5-6-1-1	36
S20135001	R - 5-6-1-2	36
S20180001	L - 29	26
S20199001	L - 14	26
	L - 16	26
	L - 18	26
	L - 30	26
S20200001	L - 30	26
S20305001	A - 2	2
S20306000	A - 5	2
S20309101	A - 11	2
S20310001	A - 13	2
S20311000	A - 14	2
S20313000	A - 20	2
S20314000	A - 21	2
S20319001	A - 27-3	2
S20320101	A - 27-5	2
S20321001	A - 27-6	2
S20323101	A - 29	2
S20324101	A - 33	2
S20325001	A - 35	2
S20327101	A - 27-8	2
S20328001	A - 37	2
S20330100	A - 39	2
S20331001	A - 40	2
S20334000	A - 43	2
S20338200	A - 61	4
S20339000	A - 62	4
S20340001	A - 69	4
S20342001	A - 70	4
S20344009	A - 74	4
S20345009	A - 10	2
	A - 75	4
S20346000	A - 80	4
S20353000	B - 21	6
S20355002	H - 9-2-2	22
S20356001	B - 11	6
S20357000	B - 30	6
S20361001	B - 17	6
S20362151	B - 18	6
S20366000	B - 23	6
S20386101	C - 7	8
S20391001	C - 7-4	8
	D - 50-26-2	14
S20392000	C - 7-5	8
	L - 34	26
S20393101	C - 8	8
S20398001	R - 7-1	36
	Ga1 - 3	43
	Ga2 - 3	44
	Ga3 - 3	45
	Ga4 - 3	46
	Ga5 - 3	47
S20400001	Ga5 - 3	47
S20402001	Ga2 - 3	44
	Ga3 - 3	45

CODE	REF.NO.	Page
S20412000	A -48	2
	A -55	4
	Z -67	40
S20413051	C -18	8
S20414001	C -20-1	8
S20415101	C -22	8
S20416101	C -23	8
S20424001	Ga1 -9	43
	Ga3 -9	45
	Ga4 -9	46
	Ga5 -9	47
S20430001	Ga2 -9	44
	Ga4 -9	46
S20432001	Ga2 -9	44
S20434001	Ga2 -9	44
S20436001	Ga1 -9	43
	Ga3 -9	45
	Ga4 -9	46
S20438101	Ga3 -9	45
S20440101	Ga5 -9	47
S20442001	Ga3 -9	45
S20453001	P -1	30
S20454000	P -1-1	30
S20455000	P -1-2	30
S20456000	P -1-5	30
S20459000	P -1-6	30
S20460000	P -1-7	30
	P -5-2	30
S20461101	P -5	30
S20464000	P -5-1	30
S20467001	P -5-5	30
S20472001	D -1	10
S20476001	D -4	10
S20477001	D -4	10
S20485001	D -19	10
S20494001	D -40-1	10
S20495001	D -36	10
S20496101	E -1	16
S20500001	E -1-2	16
S20500002	E -1-2	16
S20500003	E -1-2	16
S20507001	E -3-1	16
S20523000	E -43	16
S20524000	E -44	16
S20525001	E -45	16
S20526000	E -47	16
S20527001	E -83	18
S20530001	E -30	16
S20543101	E -51	16
S20544000	E -52	16
S20547001	E -55	18
S20548001	E -59	18
S20554001	E -58	18
S20560001	E -66	18
S20561001	E -67	18
S20571101	G -2	20
S20574001	G -8	20
S20575001	G -9-1	20
S20576001	G -9-2	20
S20577001	G -12	20
S20578101	G -13	20
S20579101	G -15-2	20
S20580101	G -17	20

CODE	REF.NO.	Page
S20582001	Ga1 -8	43
	Ga2 -8	44
	Ga3 -8	45
	Ga4 -8	46
	Ga5 -8	47
S20583001	Ga3 -8	45
S20585001	G -27	20
S20598000	H -2	22
	J -3	24
S20601001	H -5	22
S20621001	J -4	24
S20625151	J -11	24
S20627001	J -14-1	24
S20655101	L -1	26
S20656101	L -4	26
S20657001	L -4-1	26
S20658001	L -4-3	26
S20660000	L -4-4	26
S20661000	L -4-5	26
S20662100	L -4-6	26
S20663000	L -4-7	26
S20666001	L -17	26
S20668100	L -22	26
S20669000	L -24	26
S20671000	L -28	26
S20672001	M -1	28
S20673001	M -11	28
S20675001	M -8	28
S20676051	M -9	28
	R -2-1-5	32
S20677000	M -10	28
S20678001	M -14	28
S20679001	M -15	28
S20681000	M -17	28
	R -2-1-7	32
S20682101	M -18-2	28
S20682102	M -18-4	28
S20682103	M -18-1	28
S20682104	M -18-3	28
S20682105	R -2-1-8	32
S20683001	M -19	28
S20684101	M -23	28
S20685001	M -25	28
S20686001	M -26	28
S20687001	M -37	28
S20689001	M -48	28
S20690001	M -49	28
S20691001	M -50	28
S20692001	M -51	28
S20693001	M -5	28
S20718000	Z -27	40
S20719000	Z -34	40
S20721001	Z -64-1	42
S20722001	Z -64-10	42
S20740101	E -46	16
S20769000	Z -40	40
S20878000	A -19	2
	A -82	4
S20880001	Ga5 -4	47
S20881201	Ga5 -2	47
S20896101	G -15-2	20
S20897101	G -15-2	20
	Ga2 -7	44

CODE	REF.NO.	Page
S20897101	Ga4 -7	46
	Ga5 -7	47
S20898101	G -15-2	20
	Ga3 -7	45
S20899001	Ga2 -8	44
S21091000	E -81	18
S21092000	E -81-1	18
S21127001	M -38	28
S21128001	M -44	28
S21129001	M -40	28
S21130051	M -42	28
S21133001	M -28	28
S21134001	M -29	28
S21135001	M -31	28
S21136101	M -35	28
S21137001	M -33	28
S21294001	R -2-1-1	32
S21295001	R -2-1-2	32
S21297001	R -2-1-12	32
S21298001	R -2-1-15	32
S21299001	R -2-1-17	32
S21300001	R -2-1-19	32
S21301001	R -2-1-23	32
S21302001	R -2-1-24	32
S21303001	R -2-1-26	32
S21304001	R -2-1-28	32
S21305001	R -2-1-3	32
S21306001	R -2-1-13	32
S21307001	R -2-1-14	32
S21310001	R -6-1	32
S21311001	R -6-2	32
S21312001	R -6-3	32
S21313001	R -6-6	32
S21314001	R -6-7	32
	S -1-12	38
S21315001	R -6-9	32
	S -1-10	38
S21316001	R -6-11	32
	S -1-13	38
S21318000	R -5-3	36
S21320001	S -1-7-1	38
S21321001	S -1-7-5	38
S21322001	S -1-7-6	38
S21324001	S -1-7-8	38
S21325001	S -1-22	38
S21327001	S -1-16	38
S21328001	S -1-17	38
S21334001	S -1-1	38
S21335001	S -1-7	38
S21336101	Q -1	30
S21341001	Q -1-6	30
S21373101	R -3-1-1	34
S21375001	R -3-1-1-2	34
	R -3-2-1-2	34
S21376001	R -3-1-1-9	34
S21377001	R -3-1-1-11	34
	R -3-2-1-11	34
S21378001	R -3-1-1-12	34
	R -3-2-1-12	34
S21379001	R -3-1-2	34
S21380101	R -3-2-1	34
S21381001	R -3-2-2	34
S21392001	Ga3 -5	45

CODE	REF.NO.	Page
S21393001	Ga3 -5	45
S21394001	Ga3 -5	45
S21395001	Ga3 -6	45
S21590000	R -2-4	32
S21798001	Z -42-10	42
S23337009	A -7	2
S23341009	D -31	10
S23342001	C -1-2	8
	C -7-1	8
	G -1-3	20
	H -9-1-1	22
S23346101	H -1-2	22
	J -1-2	24
S23349001	R -6-13	32
	S -1-25	38
S23350001	A -63	4
S23351001	A -65	4
S23353001	Z -58	40
S23356001	Z -10	40
S23357001	A -79	4
S23360001	E -37	16
	E -42	16
S23364000	D -39	10
S23366001	L -3	26
S23367001	A -16	2
S23418002	C -21	8
	M -27	28
	P -2	30
	R -2-5	32
S23452002	M -22	28
S23453001	E -84	18
S23458101	E -7	16
S23460001	L -4-11	26
S23611101	H -15	22
S23612001	E -73	18
S23614101	J -12	24
S23615001	E -5	16
S23616101	A -25-2	2
	E -82	18
S23619001	G -6	20
	H -6	22
S23621101	E -72	18
	E -76	18
	E -78	18
	G -16-1	20
S23626001	H -7	22
	J -6	24
S23628051	E -71	18
S23651002	R -2-1-18	32
	R -5-9	36
S23773001	Q -1-2	30
S23774001	R -6-8	32
	S -1-15	38
S23775001	R -2-1-6	32
S23777101	R -2-1-4	32
S23779001	R -2-6	32
S23784001	S -1-18	38
S23786001	S -1-21	38
S23896101	Q -1-1	30
S23897001	Q -1-4	30
S24663001	Ga3 -4	45
S24664001	Ga3 -4	45
S24680001	Ga2 -5	44

CODE	REF.NO.	Page
S24681001	Ga2 -5	44
S25005001	R -2-1-9	32
S25006001	R -2-1	32
S25007001	S -1-5	38
	Ga5 -5	47
S25008001	Ga5 -5	47
S25009001	Ga5 -5	47
S25010001	S -1-6	38
	Ga5 -6	47
S25019001	R -5-8	36
S25181001	A -92	4
S25190001	Ga1 -4	43
S25191001	Ga1 -4	43
S25192001	Ga2 -4	44
S25193001	Ga1 -4	43
	Ga4 -4	46
S25526000	L -35	26
S25527001	Ga1 -4	43
S25528001	Ga2 -4	44
S25529001	Ga2 -4	44
S25530001	B -1-1	6
S25538001	R -7-3	36
	Ga4 -2	46
S25543001	Ga1 -2	43
S25544001	Ga1 -2	43
S25546001	Ga4 -2	46
S25547001	Ga4 -2	46
S25818001	E -61	18
S25879001	L -32	26
S27868001	B -16	6
S29094001	E -69	18
S29700000	H -9-3	22
S29854109	Z -42	42
S29869001	Ga3 -2	45
S29870001	D -50-19-4	14
S29871001	Ga3 -2	45
S29898101	S -1	38
S29898102	S -1	38
S29933000	P -5-3	30
S29934000	P -5-4	30
S29950001	Ga1 -2	43
S29951001	Ga1 -2	43
S29952001	Ga1 -2	43
S30134001	R -2	32
S30135101	R -3-1	34
S30135102	R -3-2	34
S30137011	R -6	32
S30291101	R -7	36
S30292101	R -7	36
S30293201	R	36
S30295201	R	36
S30303001	R -5	36
S30443001	S -1-24	38
S30517101	A -73	4
S30562000	D -28	10
	E -18	16
S30894101	Ga2 -6	44
S30898001	Ga3 -2	45
S30900001	Ga3 -2	45
S30901001	D -50-25-3	14
S30902001	D -50-25-4	14
S30903001	D -50-25-5	14
S30904001	D -50-25-6	14

CODE	REF.NO.	Page
S31107201	R	36
S31108201	R	36
S33529001	Ga5 -4	47
S33530001	Ga5 -5	47
S33531001	Ga5 -5	47
S33536001	Ga5 -6	47
S35997001	Z -29	40
	Z -64-3	42
S36007001	Z -64-4	42
S36738001	Ga1 -5	43
S36739001	Ga1 -5	43
S36740001	Ga1 -6	43
S36864001	E -3-2	18
S36866001	Ga1 -4	43
S36867001	Ga1 -2	43
S36869001	D -50-26-8	14
S36870001	D -40-2	10
S37037001	Z -42-15-3	42
	Z -42-16-3	42
S37038001	Z -42-15-2	42
	Z -42-16-2	42
S37060001	Wa	48
S37070121	D -34	10
S38312050	E -24	16
S38320100	H -9-2-1	22
S38330050	M -46	28
S38349001	Wa	48
S38350001	Wa	48
S38645001	Z -65	40
S38648001	Z -42-4-2	42
S39564021	A -23	2
S39565101	B -24	6
S39571021	C -10	8
S39577000	D -2-1	10
S39589021	E -8	16
S39593021	E -54	18
S39596021	E -54-1	18
S39607001	A -8	2
S39611001	A -27	2
S39612001	A -27-1	2
S39613001	A -27-2	2
S39625151	A -49	2
S39626021	A -58	4
S39629021	B -3	6
S39630000	B -10	6
S39631000	B -20	6
S39644021	C -2	8
S39645021	C -3	8
S39646021	C -4	8
S39647000	C -5	8
S39648021	C -9	8
S39649021	C -14	8
S39650051	C -16-1	8
S39651051	S -1-2	38
S39653051	C -24	8
S39659021	D -6	10
S39660001	D -7	10
S39661001	D -8	10
S39662001	D -9	10
S39663021	D -11	10
S39664001	D -12	10
S39665001	D -15	10
S39666001	D -20	10

CODE	REF.NO.	Page
S39669101	D -23	10
S39670000	D -24	10
S39671101	D -26	10
S39672001	D -29	10
S39674001	E -9	16
S39675001	E -10	16
S39676121	E -15	16
S39677021	E -16	16
	G -5	20
	H -4	22
	J -9	24
S39678021	E -17	16
S39679001	E -20	16
S39683000	E -26	16
S39684021	E -27	16
S39685001	E -28	16
S39690021	E -36	16
	E -41	16
S39691001	E -39	16
S39692021	E -50	16
S39694021	E -64	18
S39695001	E -65	18
S39704021	G -4	20
S39707001	G -19	20
S39708001	G -25	20
S39709021	G -28	20
S39728021	H -3	22
	J -8	24
S39769051	E -40	16
S39770001	D -17	10
S39773001	E -35	16
S40640001	Z -42-7	42
S40641001	Z -42-15	42
S40642001	Z -42-16	42
S40643001	Z -42-17	42
S40866001	J -14-2	24
S42042021	E -33	16
S43453001	A -97	4
S43521000	L -36-2	26
S43522000	L -36-1	26
S43523000	L -36	26
S43916001	E -48	16
S44535001	A -25-3	2
S44536000	A -24	2
S44821001	A -94	4
S46849001	D -21	10
S46887001	D -2	10
S46889001	D -5	10
S46891001	E -23	16
S46895001	E -68	18
S46896001	H -9	22
S46899001	C -7-2	8
	D -22	10
	H -9-1-2	22
S46900001	B -13	6
S46901001	H -9	22
S46903001	H -13	22
S46904001	J -5	24
S46905001	L -12	26
S46907001	Z -11	40
S46921001	B -1	6
S46922001	B -1	6
S46931001	C -1	8

CODE	REF.NO.	Page
S46932001	C -1	8
S46933001	G -1	20
S46940001	H -1	22
S46941001	J -1	24
S46942001	J -1	24
004350812	E -31	16
011502012	R -6-15	32
	S -1-27	38
012060632	B -25	6
	D -25	10
	E -2	16
	E -4	16
	E -73-1	18
	G -6-1	20
	H -6-1	22
	R -6-4	32
012400432	A -27-4	2
	A -32	2
	A -40-1	2
	D -30	10
	E -29	16
	H -13	22
	R -6-12	32
	S -1-14	38
012400536	L -4-2	26
012400632	A -42	2
012400832	A -31	2
	E -32	16
	S -1-7-4	38
012500536	L -2	26
014060632	Z -42-17-1	42
014780622	R -3-1-1-6	34
	R -3-2-1-6	34
017060812	H -8	22
	J -7	24
017061612	C -1-3-1	8
	G -1-2-1	20
017081606	R -3-1-1-8	34
	R -3-2-1-8	34
017085502	Z -64-5	42
017500812	G -26	20
017501212	A -64	4
017781012	R -3-1-1-4	34
	R -3-1-1-10	34
	R -3-1-1-13	34
	R -3-2-1-4	34
	R -3-2-1-10	34
	R -3-2-1-13	34
018061432	E -53	16
	H -10	22
	L -6	26
018061632	E -8-1	16
	E -34	16
	E -40-1	16
	E -60	18
018062532	B -28	6
	C -15	8
	D -13	10
018401032	R -2-3	32
018401622	C -1-1-1	8
	G -1-1	20
	H -1-1	22
	J -1-1	24

CODE	REF.NO.	Page
018401632	R -2-2	32
021060302	R -2-1-20	32
	R -2-7	32
021080106	Z -33	40
	Z -64-8	42
021400106	Z -70	40
	Z -70	40
021400202	R -3-1-3	34
	R -3-2-3	34
021400212	A -53	4
	D -18	10
	Q -1-5	30
	R -2-1-22	32
	R -6-10	32
	S -1-11	38
021500106	Z -42-10-3	42
	Z -42-15-1	42
	Z -42-16-1	42
	Z -42-17-2	42
021500303	R -6-7-1	32
021500312	R -6-16	32
	S -1-28	38
025030132	G -14	20
025040132	A -45	2
	E -49	16
	G -11	20
	P -4	30
	S -1-8	38
025040232	R -5-5	36
	S -1-19	38
025040332	Z -60	40
025050132	A -72	4
025060332	D -14	10
025080236	Z -64-6	42
025350332	A -68	4
	E -63	18
025710232	E -12	16
	E -13	16
026260136	D -50-11-9	12
028050246	Z -42-10-2	42
028060242	B -27	6
028080242	Z -32	40
	Z -64-7	42
031411304	Z -57	40
034422006	R -5-6-2	36
047250842	E -1-1	16
047301042	E -3-2-1	18
047301642	D -2-2	10
047401642	D -21-1	10
047502542	D -16	10
	E -57	18
047602042	A -54	4
048040342	E -14	16
	E -70	18
048090342	D -27	10
	E -19	16
048400242	B -14	6
060300412	D -35	10
	M -30	28
060300512	Z -92	40
060300612	D -38	10
	M -52	28
060350812	A -67	4

CODE	REF.NO.	Page
060350812	E -62	18
	J -16	24
060351012	J -15	24
060400512	A -60	4
	L -17-1	26
060400612	A -12	2
	A -27-7	2
	A -27-9	2
	A -34	2
	A -36	2
	A -46	2
	A -50	2
	A -59	4
	D -10	10
	E -22	16
	H -16	22
	M -24	28
	M -32	28
	M -36	28
	M -39	28
	M -41	28
	M -45	28
060400812	A -15	2
	A -17	2
	G -29	20
	L -11	26
	L -26	26
	L -33	26
	M -4	28
	M -20	28
	M -43	28
	R -6-14	32
	S -1-26	38
	Z -64-11	42
	Z -64-12	42
060401012	A -25-1	2
	A -47	2
	P -3	30
	S -1-9	38
060401412	A -28	2
060630412	D -50-18-5	12
060630712	E -75-1	18
061400812	A -18	2
	A -26	2
	B -6	6
	L -23	26
062060812	G -18	20
	G -21	20
062061412	Z -66	40
062300412	G -16-2	20
062300512	Q -1-7	30
	S -1-23	38
062300812	R -2-1-11	32
062350512	R -2-1-27	32
062350612	Q -1-9	30
062350812	C -7-3	8
	C -25	8
	R -6-5	32
062351016	L -4-8	26
062400612	A -30	2
	C -19	8
	R -2-1-25	32
	Z -59	40

CODE	REF.NO.	Page
062400812	A -9	2
	B -5	6
	R -2-1-16	32
	R -5-4	36
062401012	A -22	2
	B -22	6
	C -17	8
	E -6	16
	P -6	30
	Q -2	30
	R -3-1-4	34
	R -3-2-4	34
062401212	A -4	2
	A -52	4
	G -10-1	20
	S -1-20	38
062401406	Z -71	40
	Z -71	40
062401612	A -81	4
	G -10-2	20
	R -2-1-21	32
062501406	Z -42-15-4	42
062630612	D -50-11-6	12
062670712	D -41	10
	D -50-25-8	14
072600000	B -7	6
076203000	B -15	6
081005070	E -11	16
081005670	E -56	18
081008070	L -5	26
081009070	A -77	4
081020070	E -21	16
081031870	B -4	6
081044070	L -9	26
100032003	C -33	8
100136001	R -5-1-4	36
101118001	R -5-2	36
101572101	Z -5	40
102707002	R -2-8	32
104450101	C -11	8
105161004	D -3	10
105288001	D -50-10-5	12
106640001	D -50-9-2	12
	D -50-14-2	14
108494001	R -5-1-2	36
108495001	R -5-1-3	36
110832009	M -12	28
116016001	Z -72	40
	Z -72	40
116794001	S -1-7-7	38
117466000	Z -13	40
118735002	C -1-3-2	8
	G -1-2-2	20
118770001	A -44	2
122991001	Z -25	40
126863001	Z -42-3	42
138843001	Z -42-12	42
140530002	D -50-1-7	12
	D -50-2-5	12
	D -50-9-4	12
	D -50-10-7	12
	D -50-11-8	12
	D -50-19-7	14

CODE	REF.NO.	Page
140530002	D -50-26-9	14
142002001	Z -8	40
142262001	Z -24	40
142628001	E -25	16
142998001	Z -42-6	42
143767002	R -5-1	36
143980001	R -5-1-1	36
144074350	G -15-1	20
	Ga1 -7	43
	Ga2 -7	44
	Ga3 -7	45
	Ga4 -7	46
	Ga5 -7	47
144103009	M -13	28
144225002	Z -41	40
144784001	R -2-1-10	32
144875001	L -4-9	26
144876001	L -4-10	26
145277205	Z -19	40
146293001	C -6	8
146427001	C -12-1	8
	M -47	28
146592001	M -21	28
146598001	A -71	4
	Q -1-3	30
146762001	Q -1-8	30
147893009	Z -69	40
	Z -69	40
147919051	Z -48-1	40
147919052	Z -48-2	40
147942001	L -12-1	26
148084001	L -20	26
148782001	J -13	24
148797001	R -3-1-1-5	34
	R -3-2-1-5	34
148798109	R -3-1-1-7	34
	R -3-2-1-7	34
149570001	Z -9	40
150173003	Z -42-9	42
150174000	Z -42-7-1	42
150179002	Z -42-10-1	42
150180001	Z -42-1	42
150182000	Z -42-2	42
150185009	Z -42-11	42
150206002	Z -42-4-1	42
150307000	P -1-4	30
150755001	D -50-1-3	12
	D -50-2-3	12
	D -50-10-3	12
	D -50-11-3	12
	D -50-18-3	12
	D -50-19-3	14
	D -50-26-3	14
	D -50-26-7	14
151474011	Ga1 -1	43
	Ga2 -1	44
	Ga3 -1	45
	Ga4 -1	46
	Ga5 -1	47
151474014	Ga2 -1	44
	Ga4 -1	46
	Ga5 -1	47
151474018	Ga3 -1	45

CODE	REF.NO.	Page
151474039	Ga1 - 1	43
153318201	Z - 64-2	42
154841001	A - 78	4
155162001	C - 7-6	8
155162001	H - 9-1-3	22
155197101	R - 3-1-1-1	34
	R - 3-2-1-1	34
155199101	R - 3-1-1-3	34
	R - 3-2-1-3	34
155201101	R - 3-2-1-9	34
155247000	G - 3	20
	H - 11	22
	J - 10	24
155559001	B - 12	6
156112003	Z - 42-8	42
156482000	A - 51	2
158722002	J - 17	24
183797009	Z - 56	40
183798001	Z - 64	42
213650001	Z - 31	40
	Z - 64-9	42

brother®

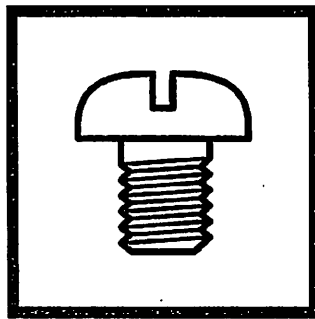

パーツブック
PARTS BOOK

ブラザー工業株式会社

〒467-8561 名古屋市瑞穂区苗代町 15 番 1 号 TEL (052) 824-2392

BROTHER INDUSTRIES, LTD

15-1, Naeshiro-cho, Mizuho-ku, Nagoya 467-8561, Japan. Phone : 81-52-824-2177

Printed in Japan

878-V5A
S97V5A-101
2002.03.C (1)

From the Library of Superior Sewing Machine & Supply LLC